

**Payment, clearing and
settlement systems in
Japan**

Contents

List of abbreviations	267
Introduction.....	269
1. Institutional aspects	271
1.1 The general institutional framework	271
1.1.1 Legal and regulatory framework	271
1.1.2 Legal basis for payment.....	273
1.1.3 Legal basis for clearing arrangements	273
1.1.4 Legal basis for securities settlement.....	274
1.1.5 Enforceability of netting arrangements.....	274
1.2 The role of the central bank	275
1.2.1 Issuance of banknotes.....	275
1.2.2 Provision of payment and settlement services	275
1.2.3 Oversight.....	276
1.2.4 Examination and monitoring	277
1.2.5 Treasury funds operations	277
1.3 The role of private and public sector bodies.....	278
1.3.1 Japanese Bankers Association (JBA) and other regional bankers’ associations.....	278
1.3.2 Japan Securities Dealers Association (JSDA)	278
1.3.3 Financial Services Agency (FSA)	279
2. Payment media used by non-banks.....	279
2.1 Cash payments.....	279
2.2 Non-cash payments.....	279
2.2.1 Non-cash payment instruments	279
2.2.2 Non-cash payment terminals	282
2.2.3 Recent developments (retail funds transfer services)	282
3. Interbank payment systems	283
3.1 General overview.....	283
3.2 Interbank payment systems	283
3.2.1 BOJ-NET Funds Transfer System (BOJ-NET FTS)	283
3.2.2 Zengin Data Telecommunication System (Zengin System).....	287
3.2.3 Foreign Exchange Yen Clearing System (FXYCS)	290
3.2.4 Bill and cheque clearing systems (BCCS) / Tokyo Clearing House.....	292
4. Systems for post-trade processing, clearing and securities settlement	294
4.1 General overview.....	294

4.2	Post-trade processing systems	294
4.2.1	Pre-Settlement Matching System (PSMS) at JASDEC	294
4.3	Central counterparties and clearing systems	295
4.3.1	Japan Securities Clearing Corporation (JSCC)	295
4.3.2	JASDEC DVP Clearing Corporation (JDCC).....	298
4.3.3	Japan Government Bond Clearing Corporation (JGBCC)	300
4.3.4	Osaka Securities Exchange (OSE)	303
4.3.5	Tokyo Financial Exchange (TFX).....	305
4.4	Securities settlement systems.....	307
4.4.1	JGB Book-entry System and BOJ-NET JGB Services	307
4.4.2	Japan Securities Depository Center (JASDEC)	309
4.5	The use of securities infrastructures by the central bank.....	311

List of abbreviations

BCCS	Bill and Cheque Clearing System
BOJ-NET	Bank of Japan Financial Network System
BOJ-NET FTS	BOJ-NET Funds Transfer System
Book-entry Transfer Act	Act Concerning Book-entry Transfer of Corporate Bonds, Shares and Other Securities
CP	Commercial Paper
FB	Financing Bill
FIEA	Financial Instruments and Exchange Act
FSA	Financial Services Agency
FXYCS	Foreign Exchange Yen Clearing System
JASDEC	Japan Securities Depository Center
JDCC	JASDEC DVP Clearing Corporation
JBA	Japanese Bankers Association
JGB	Japanese government bond
JGBCC	Japan Government Bond Clearing Corporation
JSCC	Japan Securities Clearing Corporation
JSDA	Japan Securities Dealers Association
OSE	Osaka Securities Exchange
PSA	Payment Services Act
PSMS	Pre-Settlement Matching System
Q/O account	Queuing and Offsetting Account
RTGS-XG	Next-Generation RTGS
SPDC account	Simultaneous Processing of DVP and Collateralisation Account
STRIP	Separate Trading of Registered Interest and Principal of Securities
TB	Treasury Bills
TBA	Tokyo Bankers Association
TCH	Tokyo Clearing House
TFX	Tokyo Financial Exchange
TSE	Tokyo Stock Exchange
TSEG	Tokyo Stock Exchange Group
Zengin-Net	Japanese Banks' Payment Clearing Network
Zengin System	Zengin Data Telecommunication System

Introduction

There are four major interbank payment systems in Japan: (i) the BOJ-NET Funds Transfer System (BOJ-NET FTS); (ii) the Zengin System; (iii) the Foreign Exchange Yen Clearing System (FXYCS); and (iv) the bill and cheque clearing systems (BCCS).

In November 2011, the Next-Generation RTGS (RTGS-XG) project was completed to bring new levels of safety and efficiency to large-value payments in Japan. The project consisted of two pillars: (i) the introduction of liquidity-saving features in the BOJ-NET FTS; and (ii) the migration of large-value payments to settlement on an RTGS basis in the BOJ-NET FTS. Such payments were previously processed by private sector deferred net settlement (DNS) systems, namely, the FXYCS and the Zengin System. As a result of the RTGS-XG project, large-value payments (payments in the BOJ-NET FTS, the FXYCS, and those of JPY 100 million and above in the Zengin System) are now settled on an RTGS basis. As for small-value payments (payments of less than JPY 100 million in the Zengin System and bills and cheques collected through BCCS), the net positions of participating financial institutions that are calculated by these clearing systems are settled in the BOJ-NET FTS.

For securities settlement, there are two major central securities depositories (CSDs) in Japan. The Bank of Japan is responsible for Japanese government bonds (JGBs), and the Japan Securities Depository Center (JASDEC) is responsible for all other securities, including stocks, corporate bonds, commercial paper, municipal bonds, convertible bonds, investment trusts, ETFs and REITs. With the establishment of a uniform securities settlement framework, various categories of these securities were dematerialised in JASDEC, and DVP mechanisms were adopted in a phased approach in the 2000s. To mitigate settlement risk in securities transactions, central counterparties (CCPs) were successively established in Japan after the relevant legislation was amended in 2002. These are (i) the Japan Securities Clearing Corporation (JSCC), which clears for all securities exchanges; (ii) the Japan Government Bonds Clearing Corporation (JGBCC) for JGB clearing; and (iii) the JASDEC DVP Clearing Corporation (JDCC) for the clearing of customer-side transactions in securities settled through JASDEC. In addition, the Tokyo Financial Exchange (TFX) and the Osaka Securities Exchange (OSE) internally clear transactions in listed derivatives, FX derivatives (retail margin trading of FX) and other instruments.

In retail payments, credit cards and e-money are widely used while the use of debit cards remains low. The predominance of cash for small-value payments and the almost complete absence of cheque use by individuals are the prominent features that distinguish payment practices in Japan.

Chart 1

Overview of payment and settlement systems in Japan

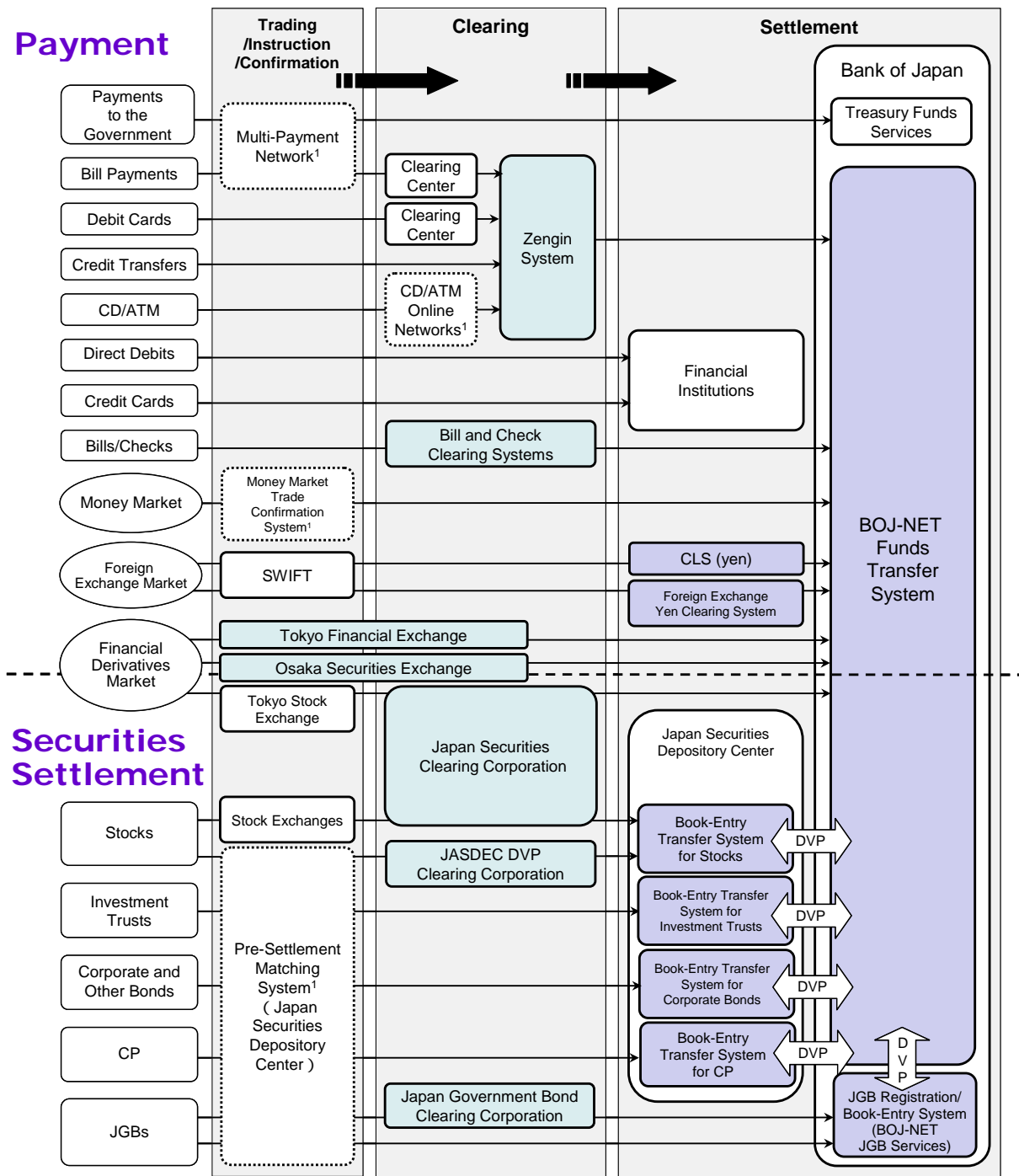

¹ Systems surrounded by the dotted line are not used for all transactions.

1. Institutional aspects

1.1 The general institutional framework

1.1.1 Legal and regulatory framework¹

1.1.1.1 General

There is no uniform or comprehensive legislation in Japan that governs payment, clearing and securities settlement. Rather, a number of laws combine to form the legal basis for payment, clearing and securities settlement.

1.1.1.2 Regulatory authorities

Most of the relevant laws governing a variety of financial sector matters specify the Prime Minister as the minister in charge. These include regulation and supervision in the areas of payment, clearing and securities settlement. In practice, the Prime Minister delegates authority to the Commissioner of the Financial Services Agency (FSA) based on the provisions of the relevant laws. For example, the FSA is the primary regulatory authority for:

- Deposit-taking services and payment services provided by licensed banks under the *Banking Act*;
- Securities-related services provided by registered financial instruments business operators such as investment firms and licensed banks under the *Financial Instruments and Exchange Act* (FIEA);
- Payment services provided by non-banks and the issuance of prepaid payment instruments under the *Payment Services Act* (PSA).

Together with the FSA, the Minister of Finance is in charge of matters related to JGBs. The Minister of Justice is also responsible for the legal and regulatory frameworks governing the book-entry transfer of securities, because these frameworks constitute a part of civil and commercial law.

1.1.1.3 Central bank

The *Bank of Japan Act* stipulates that in addition to regular business prescribed by Article 33 such as deposit-taking and funds transfers (the basic business component of the BOJ-NET Funds Transfer System), the Bank of Japan may, with authorisation from the Prime Minister and the Minister of Finance, conduct business (carried out in conjunction with its prescribed regular business) that contributes to the smooth settlement of funds. This includes operation of the Foreign Exchange Yen Clearing System and the JGB Book-entry System. In addition, the Bank of Japan oversees the payment and settlement systems operated by the private sector to achieve its objective as stipulated in Article 1 of the *Bank of Japan Act*, namely, “to ensure smooth settlement of funds among banks and other financial institutions, thereby contributing to the maintenance of the stability of the financial system” (see Section 1.2).

Against the background of the Bank of Japan’s role and functions as an overseer of the payment and settlement systems and a provider of settlement accounts to those systems, the Prime Minister can seek the Bank of Japan’s opinion, where necessary, before granting or revoking a regulatory licence for, or taking any enforcement action on, an interbank

¹ While the official texts of legislation are in Japanese, unofficial English translations are publicly available for some acts on the website operated by the Ministry of Justice, <http://www.japanlawtranslation.go.jp/re?=02>.

payment system or CCP for securities or financial derivatives (collectively referred to as “financial instrument transactions”) under the relevant legislation.²

1.1.1.4 *Payment and clearing systems*

The operator of the interbank payment system (ie the Zengin-Net) is regulated and supervised as a licensed interbank payment clearing institution by the Prime Minister under the PSA (see Section 3.2.2.1). Operators of bill and check clearing houses (eg regional bankers’ associations) are organised as non-profit incorporated associations.

The regulatory and supervisory framework for CCPs and exchanges is segmented on the basis of the assets underlying transactions. CCPs and exchanges for financial instrument transactions are regulated and supervised as licensed financial instrument clearing institutions (eg the Japan Securities Clearing Corporation) and exchanges (eg the Tokyo Stock Exchange) by the Prime Minister under the FIEA.³

The recently amended FIEA enables foreign CCPs to provide clearing services for domestic financial institutions in Japan (i) directly from abroad by obtaining a special licence; or (ii) indirectly by establishing a link with domestic financial instrument clearing institutions authorised as such. Under the amended FIEA, which will come into effect by the end of 2012, the Prime Minister can also require specified types of financial instrument transactions such as OTC derivatives to be centrally cleared by CCPs.

CCPs and exchanges for commodities (eg minerals or agricultural products) and their derivatives transactions are supervised and regulated as licensed commodity clearing organisations and exchanges by the Minister of Agriculture, Forestry and Fisheries and/or the Minister of Economy, Trade and Industry in accordance with the underlying assets under the *Commodity Futures Act*.

CCPs or exchanges can include both financial instruments and commodities in clearing services or trading lists provided they obtain both categories of licenses from the relevant ministers.

1.1.1.5 *Securities settlement systems and the credit claims transfer system*

CSDs (eg the Japan Securities Depository Center or the Bank of Japan as the JGB Book-entry System operator) are regulated and supervised as designated transfer institutions under the *Act Concerning Book-entry Transfer of Corporate Bonds, Shares and Other Securities* (the Book-entry Transfer Act)(see Sections 1.2.2.2 and 4.4.1.1).

The Book-entry Transfer Act stipulates the categories of account management institution – which include banks, cooperative depository institutions, registered financial instruments business operators, trust companies, insurance companies etc – that are allowed to hold accounts for customers in book-entry transfer systems. Under the Book-entry Transfer Act, the securities holdings of lower-tier participants and those of their customers held by participants must be recorded on the books of upper-tier participants or the CSD on an omnibus basis and separated from their own holdings. Account management institutions are also required under the FIEA to segregate securities and related funds belonging to each customer from their own securities and funds and from those of other customers.

Registrars of lists of electronic credit claim holders are regulated and supervised as designated electronic monetary claim recording institutions under the *Electronically*

² Article 86 of the Payment Services Act and Article 156-20-23 of the FIEA.

³ The definition of financial derivatives under the FIEA includes derivative transactions whose underlying assets are securities, currencies, interest rates, or an index thereof.

Recorded Monetary Claims Act, while assignments and pledges of credit claims can also be recorded on the books of public registrars (*tōki-sho*).

1.1.1.6 Trade repositories

Trade repositories (TRs) will be regulated and supervised as designated trade information repository institutions under the amended FIEA due to come into effect by the end of 2012. Financial institutions executing specified types of financial instrument transactions will be required (i) to maintain trade records and make reports to the Prime Minister; or (ii) to provide trade information to TRs. The Prime Minister can gain access to trade records maintained and stored by TRs.

1.1.2 Legal basis for payment

1.1.2.1 Payment and deposit-taking services

There is no specific civil and commercial act in Japan that specifically governs rights and obligations regarding funds transfers other than bills or cheques and deposit account transactions. They are governed by individual contractual relationships and general civil or commercial laws such as the *Civil Code* and the *Commercial Code*. The Japanese Bankers Association provides model agreements regarding payment and deposit account transactions for member financial institutions. Customer protection issues arising from the provision of payment services are handled under the relevant acts, such as the *Banking Act* or the PSA.

With respect to deposit-taking services, the *Capital Subscription Law* stipulates that all deposit-takers must be authorised under other relevant laws. Specifically, only certain categories of institution are allowed to take deposits: for example, banks are allowed to do so under the *Banking Act*, while other types of financial institution such as cooperative depository institutions do so under the respective laws governing them in this regard (eg *shinkin* banks under the *Shinkin Bank Law*).

In the case of financial derivatives, the master agreement established by ISDA is widely referred to among market participants, depending on the type of transaction.

1.1.2.2 Means of payment

Regarding means of payment, banknotes issued by the Bank of Japan and coins issued by the government have the status of legal tender under the *Bank of Japan Act* and the *Unit of Currency and Issuance of Coins Act*, respectively. Paper-based means of payment such as bills and cheques, which utilise deposit accounts for payment, are governed by the *Bill Act* and the *Cheque Act*. In addition, electronically recorded monetary claims can be utilised as electronic means of payment, which are alternatives for promissory notes, under the *Electronically Recorded Monetary Claims Act* (see Section 2.2.1.3).

Debit card services are regulated as a combination of payment services and deposit-taking services, and may be provided by licensed banks or cooperative depository institutions. In contrast, credit card services can be provided by non-banks. Credit card issuers are regulated and supervised as registered money lenders if they provide instalment or revolving loans and/or cash advance services to card holders under the *Instalment Sales Act* or the *Money-Lending Business Act*. The PSA provides the legal basis for prepaid payment instruments, including prepaid cards and chip-based or server-based electronic money, with a focus on the regulatory framework (see Section 2.2).

1.1.3 Legal basis for clearing arrangements

Legislation on clearing services (ie the PSA on interbank payment clearing, the FIEA on financial instrument clearing, and the *Commodity Futures Act* on commodity clearing) provide

the legal basis for an entity to conduct these services. These acts recognise several arrangements as the legal basis for clearing, such as the assumption of obligations⁴ and novation.

1.1.4 Legal basis for securities settlement

The Book-entry Transfer Act provides for the dematerialisation of various types of securities including government bonds, corporate bonds, commercial paper, shares, share options, convertible bonds (bonds with share options), beneficial interests in investment funds etc, and facilitates the establishment of multi-tiered book-entry systems for such securities.

Alternatively, corporate bonds, shares, share options or convertible bonds can be dematerialised on the basis of the *Companies Act* provided corporate issuers specify accordingly (i) in the terms and conditions of corporate bonds; or (ii) in their articles of incorporation for shares and share-related securities. In these cases, the names of securities holders are recorded and verified by the company registry for each type of securities.

Rights and obligations regarding the settlement of individual securities are governed by the abovementioned acts. Under these acts and in accordance with general civil or commercial laws, legal title and interests in securities are transferred or perfected via (i) credits and debits to accounts on the books of the CSD and participants for book-entry securities; (ii) changes in the names of securities or credit claim holders on the issuer's registry for other dematerialised securities; or (iii) delivery of certificates for physical securities.

In addition, the Japan Securities Dealers Association provides the model agreement and sets guidelines for outright or repurchase transactions in securities (see Section 1.3.2).

1.1.5 Enforceability of netting arrangements

Payment netting is considered to be a legally enforceable arrangement for counterparties performing their obligations under general civil or commercial laws.

Further, obligation netting (netting by novation) between two counterparties is considered to be legally enforceable even in the event of a counterparty's default under such laws, and also in insolvency proceedings against a counterparty under insolvency laws such as the *Bankruptcy Act*, the *Civil Rehabilitation Act*, and the *Corporate Reorganization Act*.

Closeout netting between two counterparties for contracts with market quotations is legally enforceable in the event of insolvency proceedings against a counterparty under insolvency laws when stipulated in the master agreement. In addition, the *Act on Closeout Netting of Specified Financial Transactions Entered into by Financial Institutions* ensures that closeout netting for specified types of financial transactions (eg financial derivatives, cash-collateralised securities lending and repurchase agreements, foreign exchange forwards and swaps, and collateral transfers for these transactions) between two counterparties is legally enforceable in the event of insolvency proceedings against a counterparty.

Multilateral netting via a CCP is legally effective and enforceable also in insolvency proceedings against a clearing participant. In particular, when a licensed clearing institution or organisation sets out in its business rules procedures for settling outstanding obligations including closeout netting and the disposition of posted collateral, such procedures are

⁴ The assumption of obligations is the process by which the CCP interposes itself between two counterparties of a financial transaction and which is stipulated in relevant laws such as the PSA or the FIEA.

legally enforceable even in insolvency proceedings against a clearing participant under the PSA, the FIEA, or the *Commodity Futures Act*.

1.2 The role of the central bank

The Bank of Japan, Japan's central bank, was founded in 1882. Article 1 of the *Bank of Japan Act* stipulates that the Bank of Japan's purposes are to issue banknotes, to carry out currency and monetary control and to ensure the smooth settlement of funds among banks and other financial institutions, thereby helping to maintain the financial system's stability. To these ends, the Bank provides various payment and settlement services such as by providing means of payment (ie banknotes and deposits in current accounts held with the Bank of Japan) and operating the BOJ-NET as the central bank's online payment and JGB settlement system. The Bank of Japan also oversees payment and settlement systems in the private sector. The responsibilities of the Bank of Japan in the field of payments and settlements are explained in the following subsections.

1.2.1 Issuance of banknotes

The Bank of Japan is the sole issuer of banknotes in Japan, and banknotes are given the status of legal tender under the *Bank of Japan Act*. In other words, they must be accepted by any creditor in satisfaction of any debt except when otherwise agreed by both the debtor and the creditor.

In order to prevent counterfeiting and alterations, banknotes embody a variety of security features. Given the surge in the number of counterfeit banknotes detected in recent years, in November 2004, the Bank of Japan began issuing a new series of Bank of Japan notes (10,000, 5,000, and 1,000 yen notes) with state-of-the-art security features. To address counterfeiting on a global basis, the Bank of Japan actively exchanges information and conducts joint studies with foreign central banks.

1.2.2 Provision of payment and settlement services

1.2.2.1 Payment through current accounts

The current account deposits of financial institutions at the Bank of Japan are used for a number of purposes including serving as settlement assets for interbank obligations. At the end of 2010, some 555 institutions, including banks, securities companies and central counterparties, held current accounts with the Bank of Japan.⁵ Since 1988, the Bank of Japan has operated an online payment system – the BOJ-NET Funds Transfer System (BOJ-NET FTS) – to process funds transfers between financial institutions through central bank accounts (see Section 3.2.1).

The Bank of Japan provides current account services to financial institutions that meet criteria, first published in 1998, specifying that applicants need to be in sound financial condition in terms of capital adequacy, must have appropriate operational capability, and must enter into a contract with the Bank of Japan under which they agree to undergo on-site examinations conducted by the Bank of Japan based on Article 44 of the *Bank of Japan Act*.

Since the start of 2001, under Article 33 of the *Bank of Japan Act*, the Bank of Japan has provided intraday overdrafts to facilitate the smooth settlement of funds through central bank accounts on an RTGS basis. In 2011, the Bank of Japan completed the Next-Generation

⁵ Participants in the BOJ-NET FTS comprise both current account holders with access to the BOJ-NET network (online participants) and those without (offline participants).

RTGS (RTGS-XG) project to bring higher levels of safety and efficiency to large-value payments (see Section 3.1). Separately, in its role as the lender of last resort, the Bank of Japan may extend loans to financial institutions experiencing liquidity constraints under Articles 33, 37 and 38 of the *Bank of Japan Act*.

1.2.2.2 Settlement of JGB transactions

The Bank of Japan has provided JGB registration services since 1906 as the sole registrar under the *Law Concerning Government Bonds*. In 1980, the Bank of Japan established the JGB Book-entry System, in which the Bank of Japan serves as the depository, to promote sound development of the JGB secondary market. In 1990, the Bank of Japan introduced an online system – BOJ-NET JGB Services – to process transfer registrations and book-entry transfers of JGBs.

The legal framework for the JGB settlement system was amended in 2003. The Bank of Japan abolished the previous JGB settlement system based on private laws such as the *Civil Code* and *Commercial Code*, as well as on contractual agreements between the Bank of Japan and system participants. It then started a new system based on the Book-entry Transfer Act, thereby achieving full dematerialisation of JGBs.

With these changes in the legal framework, several new obligations and schemes have been introduced.⁶ However, the fundamental functions of the JGB settlement system remain unchanged, so that rights in JGBs continue to be evidenced by balances recorded on the books and are transferred by crediting and debiting the accounts on these books (see Sections 1.1.1 and 4.4.1).

The Bank of Japan sets the admission requirements for participants in the JGB Book-entry System with a view to further enhancing the system's administrative transparency. These requirements specify that system participants need to be in a sound financial condition in terms of capital adequacy and to have appropriate operational capability.

1.2.3 Oversight

The Bank of Japan oversees payment and settlement systems operated by the private sector to ensure the safety and efficiency of payment and settlement arrangements in Japan.

The Bank of Japan's oversight focuses on the following types of private sector payment and settlement systems: (i) payment systems; (ii) securities settlement systems; and (iii) central counterparties. The Bank of Japan oversees payment systems to ensure safety and efficiency because the systemic risk posed by payment systems is a potential threat to the stability of the financial system and the overall economy. The Bank of Japan also oversees securities settlement systems and central counterparties on the grounds that these systems also present a systemic risk similar to that of payment systems. These systems are closely interrelated with payment systems, as they are used not only to transfer and/or clear securities and other financial products, but also include related rules and contracts for the transfer of funds provided against securities and other financial products. Although payment arrangements are needed to increase the safety and efficiency of these systems, such

⁶ If the book-entry transfer institution (CSD) or an account management institution (CSD participants) for the JGB settlement system records, for some reason, amounts larger than the correct amounts of JGBs ("overbooking"), the overbooking problem must be resolved so that the total amount of JGBs recorded in the system matches the actual outstanding amount of book-entry JGBs issued. In addition, an investor protection trust scheme was introduced to compensate retail investors for any loss or damage they suffer in the event an account-keeping institution becomes insolvent before fulfilling its obligations to resolve an overbooking problem.

arrangements give rise to systemic risk whereby disruptions in any one system can cause subsequent settlement failures in other interrelated payment systems.

The intensity of the Bank of Japan's oversight is commensurate with the size and characteristics of the risks posed by individual payment and settlement systems subject to the Bank of Japan's oversight. The Bank of Japan has a particular focus on "systemically important payment and settlement systems". Such systems, should they fail to perform as expected, could have a significant impact not only on payment and settlement systems but also on the wider financial system and the economy as a whole. Whether or not a payment and settlement system is systemically important is determined based on the following combination of factors: (i) value and number of transactions settled; (ii) number and types of system participants; (iii) characteristics of transactions settled; (iv) availability of alternative systems or payment instruments; (v) interdependencies with other systems; and (vi) relationship with the Bank of Japan.

For systems determined to be systemically important, the Bank of Japan exercises oversight by monitoring such systems, assessing them against its safety and efficiency objectives and, where necessary, inducing changes. For systems determined to be less systemically important, the Bank of Japan exercises oversight mainly by monitoring such systems in order to gain an overview of overall payment and settlement arrangements in Japan.

The Bank of Japan's oversight primarily focuses on payment and settlement systems located in Japan. However, the scope of the Bank of Japan's oversight covers offshore yen payment systems that could have a significant impact on the safety and efficiency of payment arrangements in Japan. Determining whether an offshore yen payment system has the potential to have a significant impact depends on a combination of factors including the value and volume of yen payment transactions processed by the system and the degree of interdependency between the offshore payment system and domestic payment systems. The Bank of Japan participates in the cooperative oversight of CLS and SWIFT in cooperation with other central banks.

In 2010, the Bank of Japan's Policy Board adopted and released the "*Policy on Oversight of Payment and Settlement Systems*" and the "*Policy on Oversight of Offshore Yen Payment Systems*". These policies updated the relevant policy published in 2002 with the aim of providing greater clarity on the Bank of Japan's oversight objectives and policy, while taking into account various issues including recent changes surrounding payment and settlement systems.

1.2.4 Examination and monitoring

The Bank of Japan conducts on-site examinations and off-site monitoring of financial institutions that hold current accounts with it. When making an on-site examination, in addition to analysing the institution's asset quality and profitability, the Bank of Japan evaluates the reliability and security of its computer systems and the management of settlement risks arising from participation in payment and settlement systems or from the provision of settlement services to other financial institutions. Off-site monitoring also covers issues associated with settlement activities, including financial institutions' management of their daily liquidity needs and the total value of securities eligible as collateral for credit extended by the Bank of Japan. These monitoring functions also help the Bank of Japan to fulfil a number of its other duties including the conduct of monetary policy and ensuring the smooth functioning of the overall payment and settlement system.

1.2.5 Treasury funds operations

On behalf of the central government, the Bank of Japan receives and disburses treasury funds pursuant to the *Bank of Japan Act* and the *Public Accounting Law*, as well as handling JGB-related services such as issuance, and payment of principal and interest. For example,

the Bank of Japan receives payments of national taxes and social security premiums from the general public, either indirectly via financial institutions acting as its agents⁷ or directly at its offices, and the funds collected are deposited in government accounts. The Bank of Japan also disburses treasury funds to the general public in a similar manner, including payments for public works projects and pensions (see Chart 1).

The Bank of Japan provides accounting services for government deposits held with the Bank of Japan. The Bank of Japan also sorts and calculates receipts and disbursements of treasury funds for government agencies and specific government accounts.

The Bank of Japan has taken measures to achieve more streamlined online processing for treasury funds operations for the convenience of the public and to enhance efficiency in the operations of related institutions.

1.3 The role of private and public sector bodies

1.3.1 Japanese Bankers Association (JBA) and other regional bankers' associations

The JBA represents Japan's banking industry. Its membership comprises banks, bank holding companies and regional bankers' associations. The current JBA was reorganised in April 2011 as a general incorporated association through the acquisition of the business formerly held by the Tokyo Bankers Association, the largest of the regional bankers' associations and the former Japanese Bankers Association. The JBA then took over the operations of the Tokyo Clearing House and the Foreign Exchange Yen Clearing System, and became the sole shareholder of Zengin-Net, the operator of the Zengin System.

In addition to operating payment systems, the JBA establishes market practices and standards to enhance the safety and efficiency of the industry's payment procedures. The JBA also serves as the secretariat for the SWIFT User Group of Japan and some CD/ATM networks. As of September 2011, there were 123 full member banks, three bank holding company members, 63 associate member banks and 60 special members (regional bankers' associations).

The core business of the other 60 regional bankers' associations is to conduct bill and cheque clearing among their member banks.

1.3.2 Japan Securities Dealers Association (JSDA)

The JSDA serves as an interlocutor for the securities industry. As a fully empowered self-regulatory organisation under the *Financial Instruments and Exchange Act*, the JSDA regulates market intermediaries. Its self-regulatory functions encompass rule-making, enforcement, inspection, disciplinary action, accreditation of sales representatives and dispute mediation. The JSDA also supports policy dialogue among the industry, the government, and other related parties, conducts and promotes investor relations and undertakes studies aimed at further activating the market. As of September 2011, there were 292 regular members (securities companies) and 218 special members (registered financial institutions comprising banks, insurance companies, money market dealers, credit cooperatives, government-related financials and securities finance companies etc).

⁷ With the approval of the government, the Bank of Japan enters into agency contracts with financial institutions allowing designated branches of such institutions to act as its agents for the collection and disbursement of government funds.

1.3.3 Financial Services Agency (FSA)

The FSA is responsible for ensuring the stability of Japan's financial system, the protection of depositors, insurance policyholders and securities investors, and the smooth operation of the finance sector through such measures as planning and policymaking concerning the financial system, the inspection and supervision of private sector financial institutions, and surveillance of securities transactions.

The FSA implements various policy measures to fulfil its responsibilities. It recently established the *Payment Services Act*, which allows non-banks to offer funds transfer services that only banks were previously allowed to provide and it set out the regulatory framework for interbank payment clearing institutions. As the primary regulatory authority, the FSA inspects and supervises private sector financial institutions including banks, securities companies, insurance companies, market participants and exchanges. The interbank payment clearing institution (ie Zengin-Net), financial instruments clearing institutions (ie JGBCC, JSCC, JDCC, OSE, TFX) and transfer institutions (ie the Bank of Japan and JASDEC) are also regulated by the FSA (see Sections 1.1 and 4.4.1.1). The FSA's on-site inspections are aimed at ensuring the sound and appropriate operation of financial business and at protecting consumers.

2. Payment media used by non-banks

2.1 Cash payments

Cash consists of banknotes and coins and is used more extensively in Japan than in many other advanced economies. The ratio of cash in circulation to nominal GDP, 18% at the end of 2010, was the highest among CPSS countries. At the end of 2010, banknotes in circulation totalled JPY 82 trillion (USD 1,000 billion) and coins JPY 4.5 trillion (USD 60 billion).⁸

The Bank of Japan has the exclusive authority and responsibility for issuing and circulating banknotes. Article 46 of the *Bank of Japan Act* stipulates that banknotes shall be used as legal tender for payments and that there is no limit to the acceptability of banknotes for payments (see Section 1.1.2.2). The Bank of Japan issues banknotes in four denominations: 1,000 yen, 2,000 yen, 5,000 yen and 10,000 yen. Coins are issued by the Japanese government and are put into circulation by the Bank of Japan under the *Unit of Currency and Issuance of Coins Law*. Coins come in six denominations: 1 yen, 5 yen, 10 yen, 50 yen, 100 yen and 500 yen.

2.2 Non-cash payments

2.2.1 Non-cash payment instruments

2.2.1.1 Credit transfers

Credit transfers are popular for remitting funds to a payee in a remote location, or for sending large amounts where physical delivery of cash would entail risks. Most credit transfers use electronic funds transfer systems for making intrabank or interbank payments. Interbank credit transfers are processed through private clearing systems such as the Zengin System, and sometimes directly through the BOJ-NET Funds Transfer System (see Chart 1, Sections 3.2.1 and 3.2.2).

⁸ Converted at end-of-year JPY/USD exchange rates for 2010.

Prearranged direct credits used for the payment of salaries and pensions are an example of such credit transfer services. They are based on a tri-party agreement among the payer, the payee and their banks. In the case of salaries, the firm using the service sends payroll data to its bank, and the bank transfers funds according to the data on the designated day.

2.2.1.2 *Direct debits*

Prearranged direct debits are intrabank funds transfer arrangements widely used for making a broad range of recurring payments. They are used extensively for the payment of public utility bills, credit card bills, taxes, school tuition fees, insurance premiums and loan repayments (see Chart1).

Direct debit services are provided on the basis of a tri-party agreement between the payer, the payee and their banks. The payee sends payment instructions to the bank on paper, on magnetic tape or via online transmission. On a set day, the bank debits the amount instructed from the payer's ordinary deposit account and credits the payee's account.

2.2.1.3 *Bills and cheques*

Bills are used for payments in the business sector and can be discounted by banks. Cheques are widely used by government agencies and firms, but are used only rarely for the payment of salaries, or payments by individuals (eg for the payment of credit card bills and public utility bills). Both bills and cheques are collected and exchanged between banks at regional bill and cheque clearing houses (see Chart 1 and Section 3.2.4). The volume of transactions using these paper-based instruments has recently been declining. The value of bills and cheques cleared at Tokyo Clearing House was JPY 780 trillion in 2000 and JPY 270 trillion in 2010. This trend is attributable to firms using credit transfers more widely than bills for payments, for reasons such as the stamp tax on bills, custody costs and risk of loss.

Introducing a new payment method in the business sector, electronically recorded monetary claims were created under the *Electronically Recorded Monetary Claims Act*, which came into force in December 2008. These are intended to eliminate the shortcomings of bills and facilitate financing for businesses, particularly small and medium-sized enterprises (see Section 3.2.4.7).

2.2.1.4 *Credit cards*

Credit cards are one of the most common non-cash retail payment instruments in Japan. They are used mainly for medium-value payments, with JPY 5,400 (USD 60⁹) as the average value of a credit card payment made in 2009. In recent years, credit cards have become widely used in the e-commerce market, and are also used for smaller-value payments.

In Japan, credit granted through credit cards is usually settled in full at the end of the monthly period, with no interest charged. Credit card companies provide a variety of payment options such as multiple payment plans, revolving credit, and cash dispensing and financing, but their popularity is limited. Some cards charge an annual membership fee, but customers get benefits in return such as cash-back programmes, mileage points or discounts at affiliated stores (see Chart 1).

In most cases, the Credit and Finance Information System (CAFIS), a system established by NTT Data Corporation, carries out the necessary data processing for credit card payments. When a customer presents a credit card to a member merchant, the information on the magnetic stripe or the IC chip is read by a credit authorisation terminal (CAT) and sent to the computer system of the credit card company via the CAFIS Center. The computer system

⁹ Converted at yearly average JPY/USD exchange rates for 2009.

checks for lost or stolen cards, verifies credit limits and automatically processes the purchase.

2.2.1.5 Debit cards

Debit card use remains low compared to that of other major retail payment instruments such as cash and credit cards. The average value of a debit card payment in 2009 was relatively high at JPY 56,000 (USD 600). The total value of debit card payments made in 2009 was JPY 740 billion (USD 8 billion), which is about 1/50th of that of credit cards.⁹

A nationwide debit card service called “J-Debit” is provided by the Japan Debit Card Promotion Council. The majority of financial institutions in Japan participate in J-Debit, and the service has been incorporated into most of the cash cards issued in Japan. While other retail payment instruments such as credit cards and e-money are usually available for use 24 hours a day, the J-Debit service is generally not available for a specific period during the night.

The CAFIS network is used to process J-Debit data (see Section 2.2.1.1). When customers purchase goods or services using a debit card, they insert their card into a CAT terminal and enter their personal identification number (PIN) from a keypad attached to the terminal. The transaction data are sent from the terminal to the customer’s bank via the CAFIS Center. Upon receiving the data, the bank debits the customer’s account. The CAFIS Center then sends the transaction data to the clearing centre, where net positions between banks are calculated on the day following the transaction. Two days after the transaction, interbank net positions are cleared with other interbank payments through the Zengin System or through other smaller clearing systems operating within groups of financial institutions of the same type. The member merchant’s account is credited three days or more after the transaction.

2.2.1.6 Electronic money

Used for multiple purposes, e-money is a stored value or prepaid electronic payment instrument that requires users to “load” a certain value before using it. The major e-money brands widely accepted in Japan are categorised into three groups by issuer type: (i) e-money issued by an e-money company (eg Edy); (ii) e-money issued by public transportation companies (eg Suica, PASMO); and (iii) e-money issued by retailers (eg nanaco, WAON).

Although e-money is much less widely employed than other major retail payment instruments such as cash and credit cards, its use is growing by 40–50% annually in terms of both value and number of transactions. This suggests that e-money has gained a certain level of recognition in retail payments. The total number and value of e-money transactions amounted to 0.17 billion and JPY 140 billion in June 2010, with the number of cards in circulation reaching 0.13 billion in April 2010. The use of e-money has also been favoured by the growing number of terminals and the widespread use of common terminals.

2.2.1.7 Multi-Payment Network

Multi-Payment Network (MPN) is an electronic bill payment system established by the Japan Multi-Payment Network Promotion Association (JMPA) in 2001. MPN provides a network service called “Pay-easy” which connects billers (utility companies, national and municipal government bodies) and financial institutions to process payment data for taxes, public utility bills, insurance premiums and e-commerce bills. MPN lets customers make such payments easily using ATMs, mobile phones or personal computers. It also allows billers to be notified of payment information immediately after payers have paid their bills. MPN was established and is managed through cooperation between financial institutions. Both transaction volume and value have increased steadily since the MPN service started in 2001. Some 38 million transactions worth JPY 5.7 trillion were conducted during the 2009 fiscal year (see Chart 1).

2.2.1.8 Convenience store banking

Convenience stores accept payments from customers settling their bills from public utilities and telecommunications companies, and send them to the receiving companies by way of credit transfer. In addition, ATMs that have access to the ATM services of various banks, including in some cases access to consumer finance services, have been available at convenience stores since 1999. In 2001, a bank that has no branches and relies heavily on convenience store ATMs started operations.

Such services are becoming popular due to the fact that convenience stores are more easily accessible than banks in terms of both location and business hours. Convenience stores are found everywhere and are open 24 hours a day, seven days a week, while bank windows are generally available only during bank business hours on weekdays.

2.2.2 Non-cash payment terminals

2.2.2.1 ATMs

Automated teller machines (ATMs) provide cash withdrawal and cash deposit services. They accept both banknotes and coins and process credit transfers and loans. Throughout the past few decades, banks have installed increasing numbers of ATMs, with about 140,000 machines deployed by the end of March 2009.

Banks link their in-house ATM systems with other banks' systems to enable customers to withdraw banknotes from the ATMs of peer banks. Nine major online networks have been established to date, each operated within a group of financial institutions of the same type.¹⁰ The Multi Integrated Cash Service (MICS) serves as the relay centre for the nine networks and provides nationwide ATM data transmission and clearing services. The MICS had 1,377 financial institutions as members at the end of March 2009, linking virtually every financial institution in the private sector. Interbank credit and debit positions resulting from the use of these ATM networks are calculated at the end of each business day. Interbank net positions are cleared together with other interbank payments through the Zengin System or groups' own clearing systems, and are then settled through accounts held with the Bank of Japan or with groups' central organisations. Non-banks such as life insurance companies and securities companies also have their own ATMs.

2.2.2.2 E-money terminals

The increase in the number of e-money terminals has accelerated with the expansion of e-money affiliated shops. There were 287,000 such terminals at the end of 2007 and 591,000 at the end of 2009. While each e-money brand started out by installing proprietary terminals, increasing numbers of terminals are now interoperable between brands.

2.2.3 Recent developments (retail funds transfer services)

Since the *Payment Services Act* came into force in April 2010, non-bank entities have been allowed to offer funds transfer services that only banks and other deposit-taking financial institutions were previously permitted to provide. In order to provide funds transfer services, an entity must be registered as a funds transfer service provider and is subject to regulations set by the Financial Services Agency, such as the requirement to preserve the equivalent value of funds accumulated by their customers. Just like bank deposits, funds accepted by

¹⁰ City banks, regional banks, member banks of the Second Association of Regional Banks, trust banks, long-term credit banks and the Shoko Chukin Bank, *shinkin* banks, credit cooperatives, labour credit associations and agricultural cooperatives.

funds transfer service providers are redeemable at any time and at par value, and the payment of interest on such funds is not permitted. Both one-shot services and account-based services for recurring transactions are permitted. However, the amount of funds to be transferred per customer request must not exceed JPY 1 million. As of September 2011, there were 18 registered funds transfer service providers including wireless carriers, e-commerce companies and foreign remittance service providers.

3. Interbank payment systems

3.1 General overview

There are four major interbank payment systems in Japan: (i) the BOJ-NET Funds Transfer System (BOJ-NET FTS); (ii) the Zengin System; (iii) the Foreign Exchange Yen Clearing System (FXYCS); and (iv) the bill and cheque clearing systems (BCCS). In 2010, the average value per transaction was JPY 2.1 billion (USD 23 million) for the BOJ-NET FTS, JPY 450 million (USD 5 million) for the FXYCS, JPY 1.8 million (USD 20,000) for the Zengin System and JPY 9.6 million (USD 110,000) for bills and cheques cleared by the Tokyo Clearing House, the largest bill and cheque clearing system (see Chart 1).¹¹

In November 2011, the Next-Generation RTGS (RTGS-XG) project was completed to bring new levels of safety and efficiency to large-value payments in Japan. The project consisted of two pillars: (i) the introduction of liquidity-saving features into the BOJ-NET FTS; and (ii) the migration to RTGS in the BOJ-NET FTS of large-value payments that were previously processed by private sector DNS systems, namely, the FXYCS and the Zengin System. The changes were implemented in two phases, with the introduction of liquidity-saving features into the BOJ-NET FTS and the migration of all payments in the FXYCS to RTGS taking place in Phase 1 and the migration to RTGS of large-value payments in the Zengin System taking place in Phase 2. Phase 1 was successfully implemented in October 2008 and Phase 2 in November 2011.

As a result of the RTGS-XG project, large-value payments (payments in the BOJ-NET FTS, the FXYCS, and those of JPY 100 million or more in the Zengin System) are now settled on an RTGS basis. As for small-value payments (payments smaller than JPY 100 million in the Zengin System and bills and cheques collected through BCCS), the net positions of participating financial institutions, which are calculated by these clearing systems, are settled in the BOJ-NET FTS.

3.2 Interbank payment systems

3.2.1 BOJ-NET Funds Transfer System (BOJ-NET FTS)

The Bank of Japan Financial Network System (BOJ-NET) is a computer network that transmits and processes transfer instructions. It links the Bank of Japan's computer centre, its head office/branches, and the system's participants. The BOJ-NET comprises two systems: a system for funds transfers (the BOJ-NET FTS) and a system for the settlement of JGBs (BOJ-NET JGB Services, see Section 4.4.1).

Introduced in 1988, the BOJ-NET FTS processes funds transfers through current accounts that participants hold with the Bank of Japan. In January 2001, the BOJ-NET FTS closed its DNS mode and was converted to a pure RTGS system. In November 2011, the RTGS-XG

¹¹ Converted at yearly average JPY/USD exchange rates for 2010.

project was successfully implemented (see Section 3.1). The daily volume and value of transactions settled through the BOJ-NET FTS averaged 51,000 transactions and JPY 100 trillion (USD 1,200 billion¹¹) in 2010 (see Chart 1).

3.2.1.1 Institutional framework

The BOJ-NET FTS is owned and operated by the Bank of Japan. The *Bank of Japan Act* provides the legal basis for the Bank of Japan's operation of the BOJ-NET FTS. The Bank of Japan accepts deposits and provides funds transfer services as part of its "regular business", as listed in Article 33. The Bank of Japan's provision of online services through the BOJ-NET is authorised as "business deemed to contribute to the smooth settlement of funds among financial institutions" by the Commissioner of the Financial Services Agency (FSA) and the Minister of Finance based on Article 39 and Article 61–2.

The Bank of Japan reviews the design and operation of the BOJ-NET FTS on the basis of international standards such as the *Core Principles for Systemically Important Payment Systems* drafted by the CPSS and IOSCO. Based on these review findings, the Bank of Japan then develops an improvement plan for the BOJ-NET and implements it following approval by the Policy Board. The Bank of Japan makes the plan public and seeks comment from system participants where necessary. The Operations Department and the Information System Services Department are in charge of BOJ-NET operations. The Bank of Japan's executive auditors and the Internal Auditors' Office audit the Bank of Japan's operations, including issues relating to the BOJ-NET.

3.2.1.2 Participation

The Bank of Japan has set out and published criteria for parties eligible to hold current accounts with it and have access to its lending. The criteria specify the following categories of institutions as eligible to hold current accounts with the Bank of Japan: (i) institutions playing a key role in payments; (ii) institutions playing a key role in securities settlement; and (iii) institutions playing an intermediary role in interbank money markets. Specifically, these include banks, branches of foreign banks in Japan, *shinkin* banks, central credit organisations, securities companies, securities finance companies, money market brokers, payment clearing organisations and central counterparties. The Bank of Japan requires applicants to conduct their business properly, be in sound financial condition, and have appropriate operational capability. Financial condition is assessed based on capital adequacy ratios, and specific criteria are set according to the type of institution. If the institution is a "financial institution" as defined in Article 37 of the *Bank of Japan Act*, it must also enter into a contract under which it agrees to be subject to on-site examinations by the Bank of Japan.

At the end of 2010, there were 347 online participants¹² in the BOJ-NET FTS, including 142 banks, 54 branches of foreign banks in Japan, 91 *shinkin* banks, five central organisations of cooperatives, 39 securities companies, three money market brokers, and 13 other institutions such as central counterparties.

The Bank of Japan does not generally allow for remote access, ie access by an institution that has neither its head office nor any other form of authorised establishment in Japan.

¹² Participants in the BOJ-NET FTS comprise both current account holders with access to the BOJ-NET network (online participants) and those without (offline participants). Now that most participants have access to BOJ-NET online, only a small number of regional financial institutions remain as offline participants.

3.2.1.3 Types of transaction

The BOJ-NET FTS is used for (i) funds transfers between financial institutions stemming from the interbank money market transactions, securities transactions and customer transfers; (ii) funds transfers between different accounts of the same financial institution;¹³ (iii) settlement of net positions arising from privately owned clearing systems; and (iv) funds transfers between financial institutions and the Bank of Japan, including those for open market operations. In addition to payments directly submitted to the BOJ-NET FTS, all FXYCS payments and large-value payments in the Zengin System (currently defined as payments equal to or larger than JPY 100 million) are submitted/routed to BOJ-NET FTS. Most funds transfers made through the BOJ-NET FTS are credit transfers, but in the case of in-house funds transfers, debit transfers can also be made. A sending bank can transmit a payment instruction with information regarding its and/or the receiving bank's customers.

3.2.1.4 Operation of the system and settlement procedures

All interbank transactions settled through the BOJ-NET FTS are processed on an RTGS basis. Settlement is final once the sending participant's account with the Bank of Japan is debited and the receiving participant's account is credited.

In addition to its Home Account, a participant in BOJ-NET FTS can hold a Queuing and Offsetting Account (Q/O account) and an account for Simultaneous Processing of DVP and Collateralisation (SPDC account).¹⁴ Q/O accounts, or accounts with liquidity-saving features, were introduced in October 2008 as part of the RTGS-XG project. "Queuing" allows payment instructions to be held pending within the system if a participant sends a payment instruction but does not have sufficient funds to complete the transaction. The "offsetting" mechanism searches among the newly entered and queued payment instructions for a set of instructions that can be settled when taking into account incoming funds as a source of liquidity, and settles the selected instructions simultaneously. The bilateral offsetting algorithm searches for a pair of offsetting instructions when certain events occur, including when a new payment instruction enters a system or when there is a change in Q/O account balances. The multilateral offsetting algorithm attempts to find a group of offsetting transactions from all queued instructions at five fixed times each day. As of October 2011, about 280 BOJ-NET participants had opened Q/O accounts. The types of transaction settled on Q/O accounts include payments for money market transactions, large-value payments routed from the Zengin System, and payments submitted via the FXYCS.

The operating hours of the system are from 09:00 to 17:00 for all participants and from 09:00 to 19:00 for those that have made an advance application for routine access at the later hours. Q/O accounts and SPDC accounts are available from 09:00 to 16:30. Net positions stemming from privately owned clearing systems are settled on an RTGS basis at the following times: 12:30 for BCCS and 16:15 for the Zengin System (see Chart 2).

The Bank of Japan offers BOJ-NET FTS participants several ways to access the BOJ-NET, and participants can choose the way that best suits their operations. The majority of participants access the BOJ-NET through dedicated BOJ-NET terminals with a PC-based connection. However, as an alternative to uploading and downloading files over BOJ-NET terminals, participants can also use computer-to-computer connections to streamline

¹³ Financial institutions can hold current accounts with different offices (head office and regional branches) of the Bank of Japan.

¹⁴ An SPDC account is used for the settlement of the cash legs of JGB transactions. The SPDC facility allows the receiver of JGBs to pledge the incoming securities as collateral for intraday overdrafts, while using the overdrafts to pay for those incoming securities. See Section 4.4.1.

operations with a large volume of transactions. Most major financial institutions use such computer-to-computer connections.

Chart 2
Operational timeline of BOJ-NET FTS

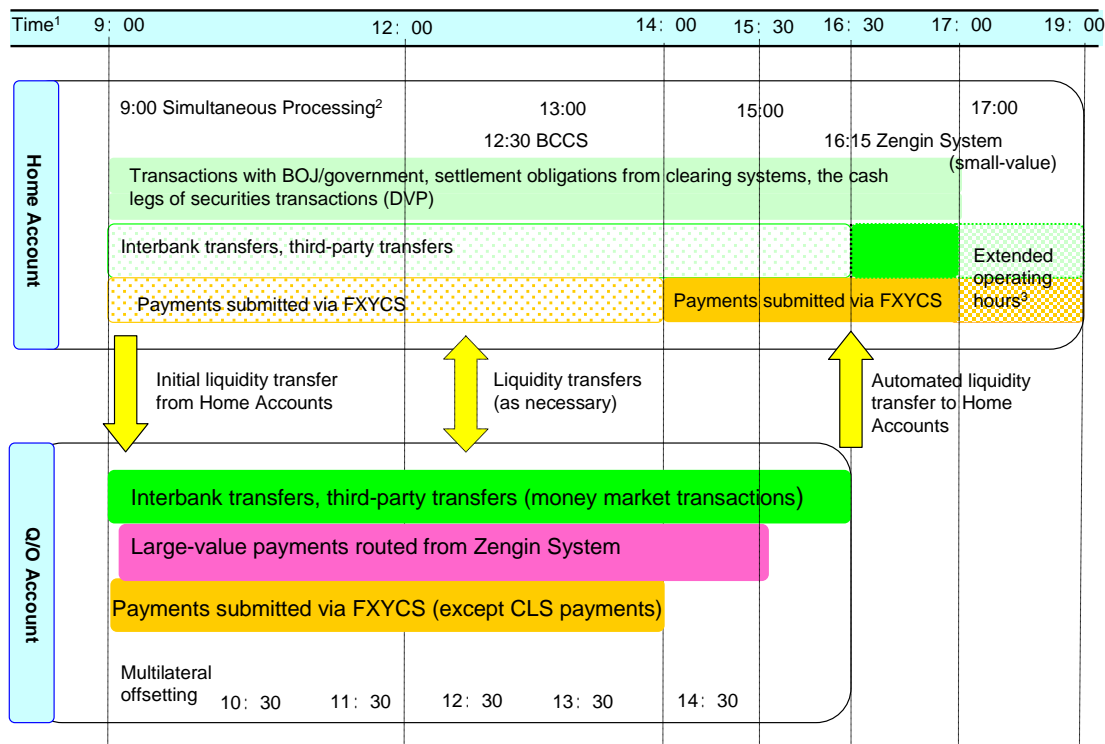

¹ Due to the high volume of settlements, a special payment schedule and extended operating hours apply on the last business day of each month. ² Some BOJ-NET FTS participants' payments to and receipts from the Bank of Japan are netted out on a bilateral basis between participants and the Bank of Japan, and the resulting net settlement positions of participants are credited to or debited from their current accounts with the Bank of Japan simultaneously and independently at designated times. This settlement mode, called "simultaneous processing", takes place at 09:00, 13:00, 15:00 and 17:00. ³ Only for participants with access to the extended operating hours.

3.2.1.5 Risk management

The Bank of Japan provides an intraday overdraft facility in order to facilitate smooth settlement on an RTGS basis. Intraday overdrafts are available on Home Accounts and SPDC accounts without charge if repaid by the end of the day. Intraday overdrafts are fully collateralised with eligible assets pledged to the Bank of Japan. Collateral is marked to market with haircuts which vary according to the type of security and residual maturity. No quantitative limit is currently imposed on the amount of an intraday overdraft.

3.2.1.6 Pricing

Of the various costs associated with the operation of BOJ-NET, the costs of linking with the BOJ-NET and for using its circuits are borne by participants, which benefit from online processing through the BOJ-NET. On the other hand, the Bank of Japan bears the cost of upgrading its operational infrastructure, including expenditure on purchasing/leasing computers and programming the BOJ-NET.

BOJ-NET participants incur a monthly fixed charge and transaction fees. The fixed charge for linking with the BOJ-NET amounts to JPY 25,300–38,300 (USD 290–440) per line per month

for terminal connections and JPY 480,000–720,000 (USD 5,500–8,200) per line for computer-to-computer connections. Transaction fees for the BOJ-NET FTS are JPY 20–60 (USD 0.20–0.70): JPY 40 (USD 0.50) for ordinary funds transfers and JPY 60 (USD 0.70) for third-party funds transfers.¹⁵

3.2.1.7 Major ongoing and future projects

As the current BOJ-NET has been in use since 1988, the Bank of Japan is in the process of developing a replacement. The new BOJ-NET will use the latest information technology; employ a more flexible architecture to take account of future changes; and have enhanced accessibility to respond to changes in the financial environment such as the globalisation of financial markets and growing interconnectedness between payment and settlement infrastructures. It will provide basically the same functions as the current system through a new system infrastructure, while some selected functions will be improved, integrated or discontinued. The Bank of Japan is currently considering the adoption of ISO 20022 messages and extending the operating hours of the BOJ-NET. The new system will start operating for some areas of the Bank of Japan's business around fiscal 2013 and for the remaining areas around fiscal 2015.

3.2.2 Zengin Data Telecommunication System (Zengin System)

The Zengin System is an interbank clearing system for domestic retail credit transfers (see Chart 1). With the completion of the Next-Generation RTGS Project in November 2011, large-value payments (defined as payments equal to or larger than JPY 100 million) in the Zengin System are settled on an RTGS basis in BOJ-NET FTS. Payments smaller than JPY 100 million continue to be settled on a DNS basis, with participants' net positions calculated by the Zengin System and settled across the accounts that participants hold with the Bank of Japan. In 2010, the system handled a daily average volume of 5.6 million transactions, while the daily clearing value averaged JPY 10 trillion (USD 120 billion¹⁶).

3.2.2.1 Institutional framework

The Zengin System started operation in 1973 with Tokyo Bankers Association (TBA) as the operator. In October 2010, the Japanese Banks' Payment Clearing Network (Zengin-Net) took over the operations of the Zengin System from the TBA (see Section 1.3.1). The Zengin-Net is regulated as a *Central Counterparty Institution for Interbank Funds Transfer* under the *Payment Services Act (PSA)*. The PSA, which has been in effect since April 2010, stipulates that only bodies that have received a license from the Prime Minister can carry out *central counterparty clearing services for interbank funds transfer*.

Zengin-Net sets rules that govern the clearing procedures of the Zengin System. It is required to consult with the Bank of Japan if any revisions are needed to rules relating to settlement or membership criteria.

3.2.2.2 Participation

The Zengin System has a two-tiered participation structure. Direct participants settle their net positions through the accounts they hold with the Bank of Japan, while indirect participants appoint direct participants to settle their net positions on their behalf. Financial institutions such as banks and branches of foreign banks in Japan participate directly in the Zengin System, and smaller financial institutions, such as cooperative financial institutions, participate in the system as indirect participants. At the end of 2010, 1,372 institutions

¹⁵ Converted at yearly average JPY/USD exchange rates for 2010.

participated in the system, of which 141 were direct participants. End users include firms and individuals.

3.2.2.3 *Types of transaction*

The Zengin System primarily clears credit transfers between two customers that hold accounts at different financial institutions. Other types of transaction handled by the system include payments resulting from the inter-regional collection of bills and cheques.

3.2.2.4 *Operation of the system and settlement procedures*

Small-value payments

Payments under JPY 100 million are processed through the Zengin System as follows (see Chart 3 below):

1. The payer instructs its sending bank to make a payment to the payee at the receiving bank.
2. The sending bank debits the payer's account.
3. The sending bank sends a transfer message to the Zengin System, which in turn sends the message to the receiving bank between 08:30 and 15:30. At the same time and on a transaction-by-transaction basis, the obligation between sending bank and receiving bank is replaced by two obligations: one between sending bank and Zengin-Net, and the other between receiving bank and Zengin-Net.
4. Upon receiving the message, the receiving bank usually credits the payee's account.
5. The net debit or credit positions between each participant and Zengin-Net are calculated within the system.
6. The Zengin System sends information on participants' net positions to the BOJ-NET FTS using the Zengin System network.
7. The net positions are settled through the BOJ-NET FTS at 16:15.¹⁶ Funds are first transferred from the accounts of Zengin System participants with net debit positions to the Zengin-Net's account and, after completion of such transfers, the funds are then transferred from the Zengin-Net's account to the accounts of participants with net credit positions. Interbank settlement is final once the net positions of participants are settled through the BOJ-NET FTS.

Large-value payments

Payments of JPY 100 million and more are processed through the Zengin System in the following manner (see Chart 3 below):

1. The payer instructs its sending bank to make a payment to the payee at the receiving bank.
2. The sending bank debits the payer's account.
3. The sending bank sends a transfer message to the Zengin System.

¹⁶ Due to the high volume of instructions flowing through the Zengin System, settlement on the last business day of each month takes place at 17:15 with the window for exchange of transfer messages extended to 16:30, and settlement on the last business day of the year takes place at 16:45 with the window for exchange of transfer messages extended to 16:00.

4. The Zengin System identifies a “large-value” payment and routes the interbank settlement information to the BOJ-NET FTS.
5. The Bank of Japan debits the sending bank’s Q/O account and credits the receiving bank’s Q/O account (see Section 3.2.1.4).
6. After receiving the notice of funds transfer from the BOJ-NET FTS, the Zengin System sends the full transfer message to the receiving bank.
7. The receiving bank credits the payee’s account.

Chart 3
Settlement process in the Zengin System

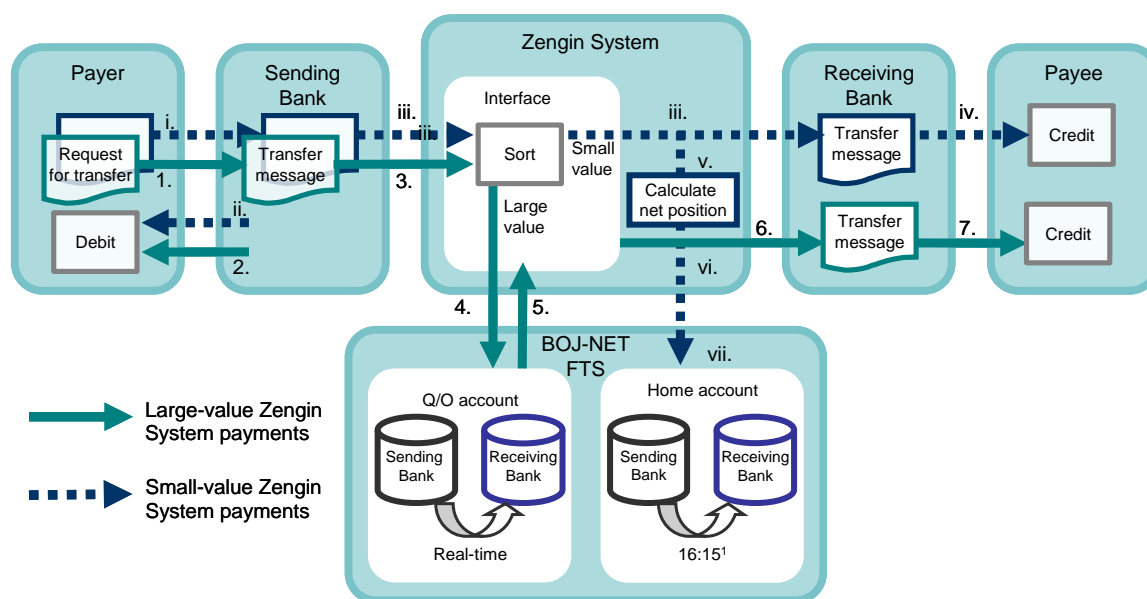

¹ Funds are transferred via the account held by the Zengin-Net with the Bank of Japan.

3.2.2.5 Risk management

For small-value payments of less than JPY 100 million, Zengin-Net acts as the CCP, and the obligations between participants are replaced by those between participants and Zengin-Net.

Each participant has a sender net debit cap, which indicates the maximum level of exposure the participant can pose to the system. Each participant is required to deposit collateral equivalent to its sender net debit cap with Zengin-Net. Each participant can substitute guarantees from other participants (“guarantor banks”) for all or part of the collateral. Guarantor banks need to deposit collateral with Zengin-Net to cover the two largest guarantees they give.

Should a participant fail to settle its net obligation, Zengin-Net completes the settlement after obtaining the necessary liquidity from banks designated in advance as “liquidity provider banks”. Under this arrangement, the 25 banks designated as liquidity provider banks would be able to cover a default by the two participants with the largest sender net debit caps. In order to repay liquidity provider banks for funds provided in an emergency, Zengin-Net can liquidate the collateral deposited by the defaulting participant. When guarantees are substituted for the defaulting participant’s collateral, the guarantor banks for that participant will provide funds to repay liquidity provider banks.

Participants in the Zengin System exchange transfer messages electronically via relay computers (RCs), which are installed either by participants or by joint centres for certain groups of financial institutions including various cooperatives.

The computer facility for the Zengin System has been updated to meet the need for increased capacity. The current computer facility, which has been in use since November 2011, is the sixth-generation facility. For operational resiliency, two main computer centres have operated separately in Tokyo and Osaka since 1987 as mutual backup facilities.

3.2.2.6 Pricing

Each participant pays an admission fee to Zengin-Net upon joining the Zengin System. The (i) operational costs of the Zengin Center, (ii) communication costs and (iii) 20% of the operational costs of each RC are borne by participants in proportion to the volume and value of their transactions. The remaining 80% of RC costs are borne by each participant that uses each RC.

3.2.3 Foreign Exchange Yen Clearing System (FXYCS)

The FXYCS was established in 1980 to facilitate the clearing of cross-border yen payments (see Chart 1). Until October 2008, the FXYCS had two settlement modes, a DNS mode and an RTGS mode. With the implementation of Phase 1 of the next-generation RTGS project, the DNS mode of the FXYCS was abolished and all FXYCS payments moved to settlement on an RTGS basis in the BOJ-NET FTS. In 2010, the system handled a daily average volume of 26,000 transactions, while the daily clearing value averaged JPY 12 trillion (USD 130 billion¹⁷).

3.2.3.1 Institutional framework

The FXYCS is owned and operated by the JBA (see Section 1.3.1). The JBA has delegated the operation of the IT system to the Bank of Japan and the processing of instructions takes place on the BOJ-NET system. The Prime Minister and the Minister of Finance have authorised the Bank of Japan to operate the FXYCS as a business that contributes to the smooth settlement of funds (see Section 1.1.1.3). The JBA lays down rules for the FXYCS that stipulate membership criteria, procedures for entry and withdrawal, and procedures for exchanging payment instructions. Any revision to the rules requires the Bank of Japan's approval.

3.2.3.2 Participation

At the end of 2010, 207 financial institutions, including 58 branches of foreign banks in Japan and CLS Bank, participated in the FXYCS. Of these, 28 were direct participants that access the BOJ-NET FTS directly, and the other 178 were indirect participants that participate in the system through direct participants. CLS Bank also has access to the BOJ-NET FTS and participates in the system with a special status short of full membership.

3.2.3.3 Types of transaction

The FXYCS handles yen payments resulting from foreign exchange transactions, yen-denominated bond transactions, transactions in the Euroyen market, as well as cross-border customer payments such as export-import payments. The FXYCS is also used to settle pay-ins and pay-outs between CLS Bank and CLS settlement members/nostro banks for the yen.

¹⁷ Converted at yearly average JPY/USD exchange rates for 2010.

3.2.3.4 Operation of the system and settlement procedures

Payments are settled on an RTGS basis in BOJ-NET FTS. Payment instructions can be submitted from 09:00 to 14:00 for RTGS with liquidity-saving features and until 17:00 for RTGS without liquidity-saving features. For the latter case, participants are allowed to submit instructions until 19:00 provided that they have applied in advance for late access.

Direct participants in the FXYCS access the system through BOJ-NET terminals installed on their premises. A direct connection between participants' host computers and the BOJ-NET host computer (computer-to-computer connection) is also available.

The following shows how payments are processed through the FXYCS (see Chart 4 below):

1. The payer in a foreign country instructs its bank to make a yen payment to the payee in Japan.
2. The payer's bank requests a funds transfer, mainly using SWIFT, to its correspondent bank (the sending bank) in Japan.
3. The sending bank sends a payment instruction to the BOJ-NET FTS via FXYCS.
4. Upon receiving the instruction, the Bank of Japan debits the amount specified in the payment instruction from the sending bank's account and credits the receiving bank's account.
5. The receiving bank credits the account of the payee.

Chart 4

Foreign Exchange Yen Clearing System

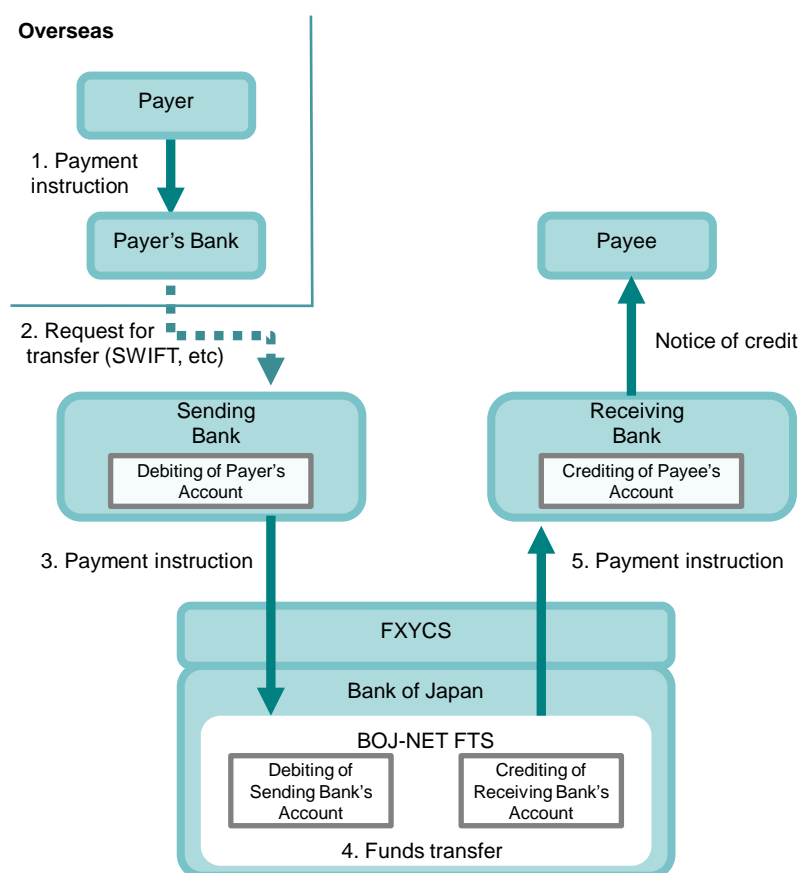

3.2.3.5 Risk management

Payments submitted to the FXYCS are settled on an RTGS basis in the BOJ-NET FTS. The rules governing the FXYCS states that all payments should in principle be submitted for settlement through accounts at the Bank of Japan with liquidity-saving features (Q/O accounts), with the exception of pay-ins and pay-outs for CLS which are settled on accounts without liquidity-saving features (see Section 3.2.1). To facilitate interbank payments and the subsequent crediting of customer accounts, the JBA has set rules that require participants to send instructions by 14:00 when using Q/O accounts. For the same reason, participants are required to send and settle, 65% of the daily volume and 55% of the daily value of payments eligible for settlement on Q/O accounts by 11:00.

3.2.3.6 Pricing policies

Financial institutions that are not members of the JBA but still use FXYCS pay admission fees to the JBA. Direct participants bear 90% of the annual operating costs, 20% of which is borne equally among them and 80% in proportion to the value of their transactions in the previous fiscal year. Indirect participants and the CLS Bank bear the remaining 10% of operating costs in equal shares.

3.2.4 Bill and cheque clearing systems (BCCS) / Tokyo Clearing House

BCCS allow financial institutions located in the same geographical area to present bills and cheques and to calculate their multilateral net positions at local clearing houses (see Chart 1). There is a long-term shift away from bills and cheques in favour of credit transfers in the Zengin System as businesses seek to avoid the cost of stamp tax¹⁸ and the cost of handling paper-based bills and cheques. As a result, the daily average value of bills and cheques processed has been trending downward since around 1990. As of January 2011, there were 243 bill and cheque clearing houses throughout Japan. The Tokyo Clearing House (TCH), which is the largest of Japan's BCCS and handles approximately 70% of bills and cheques nationwide, cleared a daily average value of JPY 1.1 trillion (USD 13 billion¹⁹) in 2010.

3.2.4.1 Institutional framework

With the exception of the TCH, which is operated by the JBA (see Section 1.3.1), the major clearing houses are owned and operated by the regional bankers' associations. Of the 243 BCCS throughout Japan, 121 have been designated by the Minister of Justice.²⁰

Although each clearing house sets its own rules, clearing houses have been encouraged to harmonise their rules to enhance the efficiency of liquidity management by financial institutions. For example, the standard settlement time of 12:30 has been adopted. Any revision to the rules of clearing houses that use central bank accounts for settlement requires the Bank of Japan's approval.

3.2.4.2 Participation

Large and medium-sized financial institutions including banks and branches of foreign banks in Japan participate in BCCS directly. Small financial institutions participate in BCCS

¹⁸ A form of tax collected by requiring a stamp to be purchased and affixed to legal documents and publications.

¹⁹ Converted at yearly average JPY/USD exchange rates for 2010.

²⁰ According to the Bill Act and the Cheque Act, presentation of bills and cheques at designated clearing houses is deemed a means of presentation for payment. Presentation of bills and cheques at non-designated clearing houses is also deemed a means of presentation for payment under agreements between the relevant parties.

indirectly through direct participants. As of December 2010, 323 institutions participated in the TCH, of which 105 were direct participants.

3.2.4.3 *Types of transaction*

BCCS mainly handle bills and cheques used for commercial transactions between firms. They also handle bills and cheques used for financial transactions.

3.2.4.4 *Operation of the system and settlement procedures*

Bills and cheques are cleared in the following manner: (1) bills and cheques are presented by payees at payees' banks; (2) bills and cheques are physically delivered and exchanged between participating banks at clearing houses; (3) the net positions of participating banks are calculated at the clearing houses; and (4) payers' banks bring back bills and cheques from the clearing houses. The net positions of participants calculated by each clearing house are settled at the settlement bank designated by the clearing house.

In the case of the 33 major clearing houses, settlement of participants' net positions takes place through the current accounts held by their respective regional bankers' associations with the Bank of Japan. Funds are first transferred from the accounts of participants with net debit positions to the account of the regional bankers' association and, after these transfers are completed, the funds are paid from the account of the regional bankers' association to the accounts of participants with net credit positions. This process is performed through the BOJ-NET FTS at 12:30 (see Section 3.2.1.4). Interbank settlement is final once the net positions of participants are settled through the BOJ-NET FTS. In general, however, the payee cannot withdraw funds until 13:00 on the business day following interbank settlement because dishonoured bills or cheques may be returned from the payer's bank to the payee's bank until 11:00 on that day.

3.2.4.5 *Risk management*

There is no limit placed upon the size of the net debit position of each participant. Should a participant fail to settle its net obligation, the clearing house is expected to promptly exclude transactions involving the defaulting participant and then recalculate the net positions of the remaining participants.

3.2.4.6 *Pricing*

In the case of the TCH, a financial institution that is not a member of the Tokyo Bankers Council pays an admission fee to become a participant in the TCH. Participants bear the operating costs of the TCH in proportion to the volume and value of their transactions during the previous fiscal year.

3.2.4.7 *Major ongoing and future projects*

A new type of instrument known as electronically recorded monetary claims has been created under the *Electronically Recorded Monetary Claims Act*, which came into force in December 2008. Electronically recorded monetary claims function in a similar way to bills as a means of financing for businesses, particularly small and medium-sized enterprises. At the same time, they eliminate the shortcomings associated with paper-based bills, which include custody costs, risk of loss, and their eligibility for stamp tax. Electronically recorded monetary claims are managed by Electronic Monetary Claim Recording Institutions in which the accruals and assignments of claims are recorded electronically. There are currently four Electronic Monetary Claim Recording Institutions in Japan: (i) the Japan Electronic Monetary Claim Organization (JEMCO) operated by the Bank of Tokyo-Mitsubishi UFJ, which started operations in 2009; (ii) the SMBC Electronic Monetary Claims Recording Co., Ltd operated by Sumitomo Mitsui Banking Corporation, which started operations in 2010; (iii) the Mizuho Electronic Monetary Claim Recording Co., Ltd operated by Mizuho Bank, which started

operations in 2010; and (iv) densai.net Co.,Ltd. to be operated by the JBA once it launches operations in 2012.

4. Systems for post-trade processing, clearing and securities settlement

4.1 General overview

There are two major CSDs in Japan. The Bank of Japan is responsible for JGBs and the Japan Securities Depository Center (JASDEC) is responsible for securities other than JGBs, including stocks, corporate bonds, commercial paper, municipal bonds, convertible bonds, investment trusts, ETFs and REITs (see Chart 1).

With the establishment of a uniform securities settlement framework, various categories of these securities have been dematerialised in JASDEC, and DVP mechanisms were adopted in a phased approach in the 2000s. For commercial paper, corporate and other bonds (municipal bonds, government-guaranteed bonds) and investment trusts, full dematerialisation was achieved in March 2003, January 2006 and January 2007, respectively. At the same time that dematerialisation was implemented, JASDEC also introduced DVP by linking individual deliveries of securities through JASDEC's Book-entry Transfer System with corresponding payments at the Bank of Japan. For stocks, DVP was achieved in a phased approach; for street-side transactions on exchanges in May 2001, for customer-side transactions in May 2004, and for stock issuance in January 2009. Full dematerialisation was achieved for stocks in January 2009.

JGB transactions are settled on a real-time DVP basis through BOJ-NET JGB Services, an online system for transferring JGBs between financial institutions. The DVP system was introduced in April 1994 and migrated to a real-time DVP system in January 2001 when the funds transfer service in the BOJ-NET Funds Transfer System (BOJ-NET FTS) also shifted to RTGS. Dematerialisation of JGBs was achieved in January 2003.

To mitigate settlement risk in securities transactions, the *Securities and Exchange Act* was amended in June 2002 to add in provisions regarding a central counterparty. After 2002, based on this amendment, CCPs were successively established in Japan. For example, the Japan Securities Clearing Corporation (JSCC) was established in 2002 as a uniform clearing institution for all securities exchanges in Japan. Prior to the establishment of the JSCC, clearing of stock transactions was carried out internally at individual exchanges. In addition, the JGBCC was established in 2003 to reduce the amount of JGB settlement under the BOJ-NET's real-time DVP system and to mitigate counterparty risk in JGB transactions. The JASDEC DVP Clearing Corporation (JDCC) was established in 2003 for customer-side transactions in securities settled in JASDEC. The Tokyo Financial Exchange (TFX) and Osaka Securities Exchange (OSE) internally clear transactions in listed derivatives, FX derivatives (retail margin trading of FX) and others. The *Financial Instruments and Exchange Act* (FIEA) came into force in September 2007 and thereafter the Act covers all central clearing businesses.

4.2 Post-trade processing systems

4.2.1 Pre-Settlement Matching System (PSMS) at JASDEC

4.2.1.1 Institutional framework

JASDEC began operating the PSMS in September 2001 to modernise and automate the matching process for various types of securities transactions. Pre-settlement matching is one of JASDEC's main businesses (see Section 4.4.2).

4.2.1.2 Participation

The PSMS is designed to work for trade matching and settlement matching process for both domestic and cross-border transactions. Users of the PSMS include securities firms, investment trusts, investment advisory firms, trust banks, custodian banks, life insurance firms and other insurance firms. Any business entity that meets a given set of requirements can, with the approval of JASDEC, acquire admissions from JASDEC and use the PSMS. There were 698 registered company users at the end of October 2011.

4.2.1.3 Types of transaction

The scope of securities and transactions covered by the PSMS is as follows.

(i) Domestic transactions

The PSMS provides trade matching and settlement matching services for domestic outright and securities financing transactions such as repo and lending and borrowing in stocks, corporate bonds, convertible bonds, JGBs, listed derivatives, commercial paper and share options.

(ii) Non-residents' transactions

The PSMS provides settlement matching services for cross-border transactions in stocks, corporate bonds, convertible bonds, JGBs and commercial paper.

4.2.1.4 Operation of the system

After accepting trade report data, the PSMS matches the trade details with the investment instructions sent from the investment managers and generates settlement instruction data. Subsequently the settlement instruction data for JASDEC eligible securities are transmitted to the JASDEC's Book-entry Transfer Systems, and finally settled by DVP through the linkage between the systems and the Bank of Japan's BOJ-NET FTS (see 4.4.2). For JGBCC eligible transactions, matched transaction data are automatically transmitted to the JGBCC (see Chart 1).

The operating hours of the PSMS are from 07:00 to 22:00.

4.2.1.5 Pricing

The PSMS system fee includes a fixed fee for participation and a variable fee proportional to the volume of transactions.

4.3 Central counterparties and clearing systems

4.3.1 Japan Securities Clearing Corporation (JSCC)

4.3.1.1 Institutional framework

The JSCC was established in July 2002 as the first nationwide central counterparty in the Japanese securities market integrating internalised clearing functions in multiple securities exchanges, and started clearing operations in January 2003. The JSCC clears transactions at Japan's six stock exchanges: the TSE, OSE, Nagoya Stock Exchange, Sapporo Securities Exchange, Fukuoka Stock Exchange and TOKYO AIM. The JSCC also clears transactions at two PTS: Japannext and Chi-X JAPAN. The JSCC launched a clearing service for iTraxx Japan index CDS in July 2011.

The JSCC issued Class A shares related to the clearing business of exchanged-traded transactions, as well as Class B shares related to the clearing business of OTC CDS transactions. The shareholders of Class A shares are Japan's five stock exchanges. The major shareholder is the Tokyo Stock Exchange Group (TSEG) of which the JSCC is a subsidiary. The shareholder of Class B shares is the TSEG.

4.3.1.2 Participation

The JSCC had 152 participants as of March 2011. Two-thirds of the participants are securities firms and the remainder are banks. The five types of clearing qualification are categorised according to tradable asset class: they comprise four for exchanged-traded transactions (Cash Products, Government Bond Futures and Futures Options, Index Futures and Options, and Individual Options), and one for OTC derivatives transactions (CDS).

The clearing qualifications for exchange-traded transactions are subdivided into Principal Clearing Qualifications and Agency Clearing Qualifications. Holders of the Principal Clearing Qualification may settle only their own transactions, while Agency Clearing Qualification holders can settle the transactions of non-clearing participants as well as their own.

The JSCC sets criteria for obtaining and maintaining qualifications, and regularly monitors participants on their management practices, operational reliability and financial standing. If a participant is observed to have significant problems in these areas, the JSCC has the right to suspend its assumption of the participant's obligations and to revoke the participant's qualifications. The JSCC can also raise margin requirements and require participants to reduce their positions when it judges that participants' positions carry excessive risk compared to their net assets and liquid assets.

The financial requirements for the acquisition of qualifications are higher than those for maintaining qualifications, and those for the agency clearing qualification are higher than those for the principal clearing qualification. These requirements are set for each type of institution. For example, the financial requirements for securities companies seeking to acquire the principal clearing qualification are (i) capital of over JPY 300 million; (ii) net assets of more than JPY 2 billion; and (iii) a capital-to-risk ratio of more than 200%.

4.3.1.3 Types of transaction

Clearing products comprise five asset classes: (i) cash products comprising stocks, convertible bonds, investment trusts, ETFs and REITs; (ii) JGB futures and futures options; (iii) stock index futures and options; (iv) equity options; and (v) index CDS. JSCC provides clearing services for all cash products including stocks, convertible bonds, ETFs and REITs traded at six stock exchanges, stocks traded at two PTS, index CDS traded in the OTC market, as well as derivatives listed on the TSE.

4.3.1.4 Operation of the system

The JSCC assumes participants' obligations and guarantees settlements. Assumption of obligations for exchange-traded transactions is conducted at the timing of every trade execution, and the assumption of obligations for CDS transactions is conducted once a week. While the JSCC carries out netting on a product-by-product basis for each participant, the amount of cash payment is netted out across products. Instructions for the securities to be transferred on a net basis are sent to JASDEC, and the funds transfer instructions on a net basis are sent to either a settlement bank or the Bank of Japan. The JSCC designates six commercial banks for cash settlement (see Chart 1).

DVP settlement is conducted through these settlement facilities on a cooperative basis. When settling cash products, participants transfer securities to a JSCC account with JASDEC by 13:00 and receive securities from a JSCC account by 14:15. Participants pay into a JSCC account with the settlement bank by 13:00 and the JSCC pays out at 14:45. This schedule allows the JSCC to (i) hold net funds until it receives the corresponding net amount of securities; and (ii) hold the net amount of securities until it receives the corresponding net funds, which obviates the need for JSCC to take on principal risk in net-net DVP (DVP3). Paid-in cash and securities transferred in advance serve as collateral, and participants can obtain securities earlier by pledging additional collateral beyond what they have to pay in, given that net-net DVP is carried out sequentially in an intraday batch system. On the other

hand, early payout is not possible. Participants settle funds using their current accounts at the Bank of Japan or settlement banks.

4.3.1.5 Risk management

The JSCC has introduced various risk management tools to protect against any default of its participants. They are categorised into three mechanisms: participant qualifications, liquidity funding and the loss allocation arrangement.

First, the JSCC has established rigorous qualifications for participation (see Section 4.3.1.2). Second, the JSCC maintains liquidity provision agreements with cash settlement banks to secure short-term liquidity enabling it to deal with potential default of participants. Finally, if the JSCC incurs loss as the result of a participant's default, financial resources will be used in the following order for exchange-traded transactions: (i) collateral including the "clearing fund" as an initial margin posted by the defaulting participant; (ii) default compensation by stock exchanges and PTS; (iii) compensation by the JSCC; and (iv) loss-sharing among non-defaulting participants. For CDS transactions, the loss allocation will take place in the following order: (i) collateral pledged by the defaulting participant; (ii) the first compensation by the JSCC; (iii) the default fund of non-defaulting participants and the second compensation by the JSCC; (iv) limited loss-sharing among non-defaulting participants; (v) compensation by non-defaulters with net gain in the accumulated amount of variation margin after the default of the participant, and others.

Participants' positions are monitored, and the JSCC has the right to either raise the requirement of collateral or require that positions be reduced.

To improve operational robustness, the JSCC introduced a backup centre in 2008 and a third office in 2009 in accordance with its business continuity plan. The JSCC has also enhanced the processing capacity of clearing systems on an annual basis in line with the growth in transaction volumes.

4.3.1.6 Links to other systems

The JSCC has links to the BOJ-NET FTS and the JASDEC Book-entry System to ensure DVP settlement. The JSCC does not have cross-margin arrangements across CCPs and does not maintain cross-border arrangements or clearing links with overseas securities settlement systems (see Chart 1).

4.3.1.7 Pricing

The JSCC charges clearing fees for cash securities based on both transaction amount and volume. Previously, fees were charged according to the value of transactions alone, but the JSCC changed its pricing policy to a dual fee system in 2006 and gradually began placing a larger weight on transaction volume because recent increases in small orders at exchanges had resulted in more costly system investments. For exchange-traded derivatives, the fee system changed completely from a transaction amount basis to a volume basis in 2009. Clearing fees for CDS transactions are based on the notional amount.

4.3.1.8 Major ongoing and future projects

The JSCC plans to provide clearing services for OTC derivatives of interest rate swaps and credit default swaps. The JSCC has set up a "Working Group on Clearing Operations for OTC Derivatives Trades" and is designing a specific operating model and system structure. Among these projects, the clearing service for iTraxx Japan started in July 2011.

4.3.2 JASDEC DVP Clearing Corporation (JDCC)

4.3.2.1 Institutional framework

The JDCC was established by JASDEC in June 2003 to achieve DVP settlement for customer-side transactions (transactions between securities dealers and institutional investors). In April 2004, the JDCC was licensed as a clearing organisation in Japan to assume participants' obligations. The JDCC started operations in May 2004. The JDCC is a wholly owned subsidiary of JASDEC.

4.3.2.2 Participation

The JDCC sets out eligibility criteria for participation ("participation criteria") specifying that an applicant must: (i) have a JASDEC account and access to its pre-settlement matching system "PSMS"; (ii) be of sound financial condition, which is assessed based on the size of capital, the size of net assets and the capital requirement ratio applicable for the specific type of financial institution including securities firms, banks and insurance companies; and (3) have sound management practices and appropriate business operations.

The JDCC currently has approximately 60 participants comprising securities firms and institutional investors such as trust banks and custodian banks.

The JDCC also defines suspension criteria and regularly monitors participants for their financial standing and ability to conduct business. If there are significant problems that might trigger the suspension criteria, the JDCC has the right to suspend its assumption of participants' obligations and to revoke participants' qualifications. Participation requirements are set at a higher level than suspension criteria.

4.3.2.3 Types of transaction

The JDCC provides the clearing services for customer-side transactions in (i) stocks etc eligible for the JASDEC book-entry transfer business, namely stocks, stock acquisition rights, corporate bonds with stock acquisition rights, investment units, preferred equity investments, investment trust beneficial rights, and other beneficial rights, as well as (ii) foreign stock certificates etc handled by JASDEC.

4.3.2.4 Operation of the system

The JDCC assumes participants' obligations until 13:50 on the settlement day provided that the order satisfies the "transfer conditions" given under the risk management scheme (see below). DVP settlement is executed on a gross-net basis (DVP2). That is, accepted orders are netted and all settlement amounts are fixed at 14:00. Net cash paying participants must complete payment to the JDCC by 15:10 (pay-in). After the payment of settlement amounts from all paying participants, the JDCC makes payments to net cash receiving participants until 15:30 (payout). Meanwhile, transfers of securities are sequentially executed on a gross basis provided that the DVP transfer order satisfies the "transfer conditions" for transfers from participants to the JDCC and the "completion conditions" for transfers from the JDCC to participants. The cut-off time for transfers from participants to the JDCC is 14:00, prior to net cash payments. The JDCC transfers securities to participants by 15:10.

The transfer conditions allowing for the assumption of obligations comprise three requirements: (i) the net payment amount is less than or equal to the assets held by the JDCC; (ii) the net payment amount is less than or equal to the upper limit given by the JDCC; and (iii) the outstanding amount of securities held by a transferring participant, including

securities which will be received on the same settlement day,²¹ is sufficient to complete the transfer. The abovementioned assets held by the JDCC comprise: (i) securities which have been delivered to the JDCC but have not yet been received by the net paying participant (so-called securities-to-be-received); and (ii) collateral securities (pledged securities) and cash deposits (within the participants' fund and the settlement facilitation payment) both posted by the net paying participant. In sum, the JDCC utilises these securities as collateral for the scheduled payment from the participant, and any shortfall in the value of collateral due to a haircut is made up for by prefunded securities and cash.

The completion conditions also comprise three requirements. Gross settlements of securities are executed sequentially once any one of these requirements is satisfied, namely: (i) a securities receiver is identified to be a net receiver of the payment; (ii) a securities receiver is identified to be a net payer and the payment is completed; and (iii) in the event that securities that will be received are due to be transferred onwards to other participants, the second transfer order satisfies the transfer conditions.

Participants settle funds using their current accounts at the Bank of Japan or their settling banks' current accounts at the Bank of Japan (see Chart 1).

4.3.2.5 Risk management

Risk management scheme

The JDCC has introduced various structures to mitigate credit and liquidity risk. The transfer conditions described above represent the principal means of mitigating credit and liquidity risks. This section shows how the three requirements comprising the conditions work from the risk management perspective.

(i) Collateral assets to cover failure of payment

The JDCC requires participants to ensure that the net payment amount is less than or equal to the assets held by the JDCC as already posted or to be received by the paying participant in question. If a paying participant fails to pay, these assets are used to compensate the JDCC for any loss it suffers as a result of the failure. As the securities held by the JDCC that are scheduled to be transferred to the defaulting participant serve as collateral, and as the time from the assumption of transfer orders to settlement is very short, ie a few hours, the JDCC does not require a margin. The value of collateral securities is set by applying a deep haircut to the previous day's market price. The JDCC also uses supplementary cash deposits and collateral securities. Since securities are transferred from participants to the JDCC on a gross basis prior to net cash payments, the collateral is always secured for the JDCC.

(ii) Limit on the net payment amount

Because the JDCC sets a limit on the net payment amount of an individual participant, the JDCC's exposure in the event of the failure of a single participant is capped at this limit. This serves to limit the JDCC's liquidity funding needs in the event of a participant's failure to pay. To satisfy liquidity funding needs, the JDCC has credit lines from banks and can use cash deposits from participants, the participants' funds.²²

(iii) Outstanding amount of transferable securities

²¹ These refer to securities balances which have been delivered to JDCC and are due to be received by the transferring participant.

²² By disposing of the holding assets of the defaulting participant, the JDCC (i) repays bank lending and (ii) restores the balance of the participants' fund.

The JDCC requires the transferring participant to maintain a securities balance greater than the volume of securities required for transfer. This requirement prevents the JDCC from being exposed to participants' failure to settle ex ante.

Loss allocation scheme

Cash deposits from defaulting participants are the first source of loss allocation and disposals of their securities collateral are the second. Large potential losses can exceed the sum of these two sources, even though securities collateral is deeply discounted with a high haircut ratio. In this case, transferring participants that are original counterparties of the defaulting participant must share the remaining loss in proportion to their settlement amount with the defaulting participant. If a participant with this obligation cannot fulfil the obligation, the participant is considered to have failed to settle and all other participants must share the residual loss.

4.3.2.6 Links to other systems

The JDCC has links to the BOJ-NET FTS and the JASDEC Book-entry System to ensure DVP settlement. The JDCC does not have cross-margin arrangements across CCPs and does not maintain cross-border arrangements or clearing links with overseas securities settlement systems.

4.3.2.7 Pricing

The JDCC charges its participants user fees based on their transaction volume and a fixed minimum charge.

4.3.2.8 Major ongoing and future projects

To support DVP settlement for stock lending transactions, the JDCC and JASDEC are cooperating with a working group of their participants to discuss a possible settlement scheme for stock lending transactions. The DVP settlement outline was fixed in 2011, and operations are expected to begin in 2014.

4.3.3 Japan Government Bond Clearing Corporation (JGBCC)

4.3.3.1 Institutional framework

The JGBCC was established in October 2003 as a central counterparty for Japanese government bonds and started clearing operations in May 2005. The backdrop to its establishment was the change in the settlement method of BOJ-NET JGB Services from DNS to RTGS in 2001. The JGBCC requires clearing participants to be shareholders of the JGBCC. Previously, the JGBCC was wholly owned by its participants. Since September 2010, 35.6% has been owned by the JSCC and the rest by the participants.

4.3.3.2 Participation

As of August 2011, the JGBCC had 35 clearing participants comprising 25 securities firms, five banks, three money market brokers and two other financial institutions.

The JGBCC sets the criteria by which participants obtain and maintain their qualifications and it regularly monitors participants on their management practices, operational reliability, and financial standing. The JGBCC delegates the monitoring of participants' financial standing to the JSCC with a view to easing the burden on participants that participate in both CCPs. The financial requirements for acquiring qualifications are higher than those for maintaining them. These requirements are set for each type of institution. For example, the financial requirements for securities companies seeking to acquire qualifications are (i) capital of not less than JPY 300 million; (ii) net assets of not less than JPY 5 billion; and (iii) a capital-to-risk ratio of more than 200%.

The JGBCC has the right to suspend its assumption of participants' obligations and to revoke their qualifications.

4.3.3.3 *Types of transaction*

The JGBCC clears outright and repo transactions in JGBs that are executed between participants in the OTC market. The term of repo transactions subject to clearing by the JGBCC is less than one year. The types of JGB eligible for clearing include FBs (Financing Bills), TBs (Treasury Bills), interest-bearing bonds, discount bonds, floating rate bonds and STRIPs (Separate Trading of Registered Interest and Principal of Securities).

4.3.3.4 *Operation of the system*

The clearing process is as follows (see Chart 1).

1. A seller and a buyer of a JGB transaction transmit trade data to the matching system, PSMS, operated by JASDEC.
2. PSMS matches and confirms the trade information and sends the confirmation results to the JGBCC.
3. At 18:30 on the trade date, the JGBCC assumes participants' obligations, and becomes the seller to every buyer and the buyer to every seller.
4. Transactions between the JGBCC and each participant are netted into one position by the type of security and by settlement date. As the standard settlement cycle for JGBs is T+2, the JGBCC typically takes on counterparty risk for two days for an outright trade.
5. The JGBCC notifies participants of the net positions and the settlement details for the following day.
6. On the settlement date, both the seller and the buyer settle their resulting net positions on a DVP basis through the BOJ-NET FTS and BOJ-NET JGB Services using the simultaneous processing of DVP and collateralisation (SPDC) function (see Section 4.4.1). There are two steps involved in DVP settlement. In the first step, the seller delivers JGBs to the JGBCC, which pledges them to the Bank of Japan as collateral for an intraday overdraft. At the same time, the JGBCC pays for the JGBs received from the seller with the funds provided by the overdraft. In the second step, the buyer makes its payment for the JGBs to the JGBCC, which in turn repays the intraday overdraft to the Bank of Japan using the payment so received. At the same time, the JGBCC receives the pledged JGBs from the Bank of Japan and delivers the JGBs to the buyer. In the collateralisation process, the amount of the haircut is offset by the collateral pledged to the Bank of Japan in advance.

By using RTGS systems for settlement of both funds and securities, the JGBCC adopts gross-gross DVP (DVP1), with net positions of both funds and securities calculated for each type of securities. The JGBCC sets the deadlines for DVP1 and DVP2 at 13:30 and 14:00, respectively. In practice, however, settlement of almost all net positions is completed in the morning in line with the market guidelines for settlement of JGB transactions.

Funds only settlement (FOS) takes place over the BOJ-NET FTS. Variation margin calls comprise a major part of FOS. Market prices are used as the clearing prices for individual securities, and differences between trade prices and clearing prices are adjusted in FOS.

4.3.3.5 *Risk management*

The JGBCC has various procedures to mitigate credit and liquidity risk. In the event that the defaulting participant's "clearing fund deposits" as initial margin are insufficient to cover the loss, the following financial resources are applied: (i) funds from participants who are original counterparties of the defaulting participant to share the remaining loss in proportion to their

net settlement amount with the defaulting participant; (ii) a quarter of the retained earnings of the JGBCC; and (iii) additional funds from all non-defaulting participants.

The clearing fund as initial margin plays a key role in covering any loss that may arise from the default of a participant. The margin calculation method is therefore set conservatively with some backups against volatility in both prices and positions. The amount of initial margin is subject to downward rigidity such that once the amount of the initial margin goes up due to a rise in price volatility and/or an increased position, the highest watermark continues to hold for a substantial period of time. In addition, the required amount based on daily figures is designed to cover the average of recent peak values in these figures. The first-loss sharing scheme (that is, participants who are original counterparties of the defaulting participant are required to deposit additional funds in proportion to their net settlement amount with the defaulting participant) is likely to discourage participants from trading with a counterparty with a deteriorating financial condition, but the margin model imposes a higher margin for a decreasing position, which results in a secure margin policy. Clearing funds may be provided in yen cash or JGBs.

Participants with a shortfall in FOS and clearing funds are required to deliver the necessary amount of funds or collateral by 10:00 and 11:00 on the following business day, respectively. Clearing funds are also designed to cover the risk of failure by a participant to make the FOS payment, which includes variation margin. The JGBCC can also raise margin requirements when the financial condition of a participant deteriorates.

The JGBCC has arrangements for addressing liquidity risk in the event of a participant's default. The JGBCC obtains liquidity from: (i) cash portion of the clearing funds; (ii) funding from markets or participants with T+0 repos, using JGBs received from non-defaulting participants and JGBs pledged as clearing funds; and (iii) drawdown of committed lines of credit. Participants who are the original counterparties of the defaulting participant are obliged to conduct T+0 repo transactions with the JGBCC when it has a liquidity shortfall.

4.3.3.6 Links to other systems

Settlement of the net positions in the JGBCC takes place on a DVP basis over the BOJ-NET FTS and the BOJ-NET Book-entry System, using the current account and JGB account that the JGBCC holds with the Bank of Japan. The SPDC function provided through these systems plays a key role in realising DVP under RTGS.

The JGBCC also has a link to the PSMS operated by JASDEC to receive confirmation results for trades executed between clearing participants. The JGBCC does not have cross-margin arrangements across CCPs and does not maintain cross-border arrangements or clearing links with overseas securities settlement systems.

4.3.3.7 Pricing

The JGBCC charges participants with clearing fees based on the value of transactions cleared for each participant, which is subject to a maximum amount. Settlement fees are set at a fixed rate per DVP transaction. These fee rates vary depending on transaction type, including whether the transaction is an outright or a repo transaction. The JGBCC also charges fees for counterparty risk based on the net outstanding positions. Such fees are charged mainly for term repo transactions. There are also fixed fees for maintaining an account and terminals.

4.3.3.8 Major ongoing and future projects

The JGBCC currently clears approximately 40% of the JGB market (outright and repo transactions). Based on the experience of the financial crisis in 2008, it has been suggested that a wider range of market participants make use of the JGBCC in order to expand the risk reduction and efficiency benefits of CCP across the JGB market. Trust banks were identified as a segment with a low participation in the JGBCC despite their large market presence. In

December 2010, the JGBCC agreed with the Trust Companies Association of Japan that it would make necessary changes to its systems and processes to facilitate trust banks' participation. In turn, the association agreed that the trust banks would aim to participate in the JGBCC in the first half of fiscal 2014 for transactions associated with their asset administration services.

4.3.4 Osaka Securities Exchange (OSE)

4.3.4.1 Institutional framework

The OSE outsourced its clearing service for cash securities to the JSCC when the latter was established with the aim of integrating the internal clearing functions of securities exchanges across the country. However, the OSE still provides clearing services for exchange-traded derivatives listed on the OSE.

Founded in 1878, the OSE was converted from a membership organisation to a joint stock corporation in April 2001 with a view to improving its international competitiveness following an amendment of the *Securities and Exchange Act* that allowed stock exchanges to transform their corporate structure.

4.3.4.2 Participation

As of June 2011, there were 94 participants, mainly securities companies. There are two clearing membership qualifications: one for stock index futures and options trading and equity options trading, and the other for FX derivatives trading. There are also two types of clearing qualifications, that is, the principal clearing qualification entitling the member to settle its own transactions only, and the agency clearing qualification entitling the member to settle the transactions of non-clearing participants in addition to its own.

The OSE sets the criteria for obtaining and maintaining these qualifications. The OSE regularly monitors participants for their operational reliability and financial standing. If a participant is observed to have significant problems in relation to these issues and to hold excessive positions, the OSE has the right to suspend its assumption of the participant's obligations and revoke the participant's qualification (see Section 4.3.4.5).

Financial standards for the acquisition of qualifications are higher than those for their maintenance, and those for the agency clearing qualification are higher than those for the principal clearing qualification. For example, the financial standards for securities companies seeking to acquire the principal clearing qualification are: (i) no less than JPY 300 million in capital; (ii) no less than JPY 2 billion in net assets; and (iii) a capital-to-risk ratio of more than 200%.

4.3.4.3 Types of transaction

Eligible products for listed derivatives are: (i) stock index futures and options such as Nikkei 225 Futures; (ii) equity options; (iii) FX derivatives (margin contracts on rolling spot futures). FX derivatives included eight yen-denominated currency products and three non-yen-denominated currency products as of June 2011.

4.3.4.4 Operation of the system and settlement procedures

The OSE assumes participants' obligations at the time of trade execution. Participants are informed of netting results, and net cash settlements for option premiums, option execution results, marking to market of futures positions, and final settlement on expiration date are executed until 13:00 on the day following the trade/mark to market for payments to the OSE and just after 14:45 for payments to participants. Fund transfer instructions are sent to either settlement banks or the Bank of Japan. The OSE designates five commercial banks for cash settlement. Securities settlements for equity options are cleared at the JSCC, and equities are transferred at JASDEC (see Chart 1).

4.3.4.5 Risk management

The OSE manages credit risk vis-à-vis participants by setting participant qualifications, and through frequent intraday measurements of risk exposure and a loss allocation scheme.

The OSE monitors risk exposure on an almost hourly basis, estimating the potential loss for individual participants from their positions of stock index futures and options trading, equity options trading and FX derivatives trading. The risk exposure to a participant is calculated as the gap between the amount of margin posted by the participant and the maximum loss estimated according to its net positions in derivative products and a high confidence level of price fluctuation over a long-term period (eg the third standard deviation of the two-day price change ratio through a sample period of more than 25 years with regard to stock index futures and options). If the risk exposure exceeds a set level in comparison with the participant's net assets, the OSE confirms the details of its positions including those with clients, focusing on concentration risk for specific clients. If necessary, the OSE recommends that the participant improve its risk management and monitors progress. In the absence of improvements, the OSE examines the participant and can ultimately raise its margin requirement or haircut on collateral and order that its positions be reduced in a stepwise manner.

The loss allocation scheme at the OSE comprises: (i) the defaulter's "clearing margin"; (ii) the defaulter's "clearing deposit" as default fund; (iii) the default compensation reserve fund owned by the OSE; (iv-a) accumulated OSE income; (iv-b) remaining "clearing deposits" of non-defaulters; and (v) loss-sharing among non-defaulters. The financial resources described in (iv-a) and (iv-b) are paid out concurrently in the same amounts to cover losses beyond the sum of (i), (ii) and (iii).

The OSE uses SPAN to calculate the amount of clearing margin. Margin must be posted by 12:00 on the day following the margin requirement. Emergency margin calls are triggered by large price fluctuations and require participants to post their margin by 16:00 on the same day.

The OSE prepares for liquidity risk in the event of a participant's default by having liquidity on hand, overdraft arrangements and committed lines of credit from commercial banks.

4.3.4.6 Links to other systems

The OSE has links to the BOJ-NET FTS for funds transfers, the JSCC to clear cash securities, and the JASDEC Book-entry System to ensure DVP settlement. The OSE does not have cross-margin arrangements across CCPs, nor does it have cross-border arrangements or clearing links with overseas settlement systems.

4.3.4.7 Pricing

The OSE adjusts its clearing fees based on values of transactions cleared measured by units of derivative trading. These fee rates differ (i) among derivative products; and (ii) among clearing for final settlement on expiration date, clearing for options execution and other types of clearing. Transaction fees are also charged in proportion to transaction values. The OSE has introduced discount systems for transaction fee rates based on average transaction value over the last three months.

4.3.4.8 Major ongoing and future projects

The OSE launched the new J-GATE derivatives trading system in February 2011 with a globally competitive high latency, a co-location service and globally accepted trading rules. The OSE has extended night session trading hours to 03:00 on the following day, and trading value during the session is increasing. The OSE abolished the 11:00 to 12:30 lunch break for stock index futures and options trading and equity options trading in February 2011. Since then, trading volume during that period has occasionally accounted for 20–30% of a day's

trading volume. FX derivatives were launched in July 2009, and trading volume has increased due to a rising number of participants and market-maker enhancements. The OSE is examining the possibility of extending night session trading hours and introducing new derivative products such as volatility index derivatives and foreign stock index derivatives.

4.3.5 Tokyo Financial Exchange (TFX)

4.3.5.1 Institutional framework

TFX provides in-house clearing services for exchange-traded derivatives listed on TFX.

In April 1989, the Tokyo International Financial Futures Exchange (TIFFE) – the predecessor of the TFX – was established under the *Financial Futures Trading Act* as a membership organisation with capital provided by large domestic and foreign financial institutions. It started trading and clearing services for euroyen/eurodollar futures and yen/dollar currency futures, expanding its range of derivative products and maturities in line with the increasing number of derivatives markets. The TIFFE was demutualised in April 2004 and was renamed as the Tokyo Financial Exchange in September 2007. This reflected a decision to broaden its business from derivatives to various other financial products when the *Financial Futures Trading Act* was abolished and incorporated into the *Financial Instruments and Exchange Act* as an amendment of the *Securities and Exchange Act*.

While demand for short-term interest rate derivatives remains subdued in markets with near-zero rates and low volatility, FX derivatives introduced in 2005 are growing rapidly as one of the TFX's core businesses.

4.3.5.2 Participation

There were 46 clearing members for the major derivative products of interest rate futures as of August 2011. Most of the members are banks and securities companies including foreign financial institutions. Three participants have a trade membership but no clearing membership, relying on other members to clear their trades. One of these uses remote trading from an overseas location. There were 28 clearing members for FX derivatives and 10 clearing members for equity index derivatives as of August 2011, mainly comprising retail-oriented securities companies for both products. Capital participation is not required for membership, and most current equity holders are original members from the membership organisation phase.

The TFX sets criteria for the acquisition of qualifications. The TFX regularly monitors participants for their operational reliability and financial standing. If a participant is observed to have significant problems in relation to these issues, the TFX has the right to suspend its assumption of the participant's obligations and revoke the participant's qualification.

Financial requirements for qualifications differ according to the scale of the participant's net assets. The smaller the participant, the more stringent and numerous the requirements imposed for membership; for example, the size of the participant's parent company, company guarantees, and experience as a clearing member in other derivatives exchanges. There are common requirements such as that the net asset value to book value ratio has to be above one and stable earnings are expected. To qualify for FX derivatives, a minimum annual trade volume is required and financial conditions must also be met.

4.3.5.3 Types of transaction

Clearing products for listed derivatives are: (i) three-month euroyen futures; (ii) options on three-month euroyen futures; (iii) overnight call rate futures; (iv) spot-next GC repo rate futures; (v) FX derivatives (margin contracts of rolling spot futures); and (vi) equity index derivatives (margin contracts on rolling spot futures). FX derivatives included 15 yen-denominated currency products and 11 non-yen-denominated currency products as of August 2011. Equity index derivatives include four indices: the Nikkei 225, the DAX, the

FTSE 100 and the FTSE China 25. The TFX also clears trades in three-month euroyen futures listed on NYSE Liffe.

4.3.5.4 Operation of the system and settlement procedures

The TFX assumes participants' obligations at the time of trade execution. For interest rate derivatives, participants are informed of netting results on the evening of trade date, and net cash settlements for option premiums, option execution results, marking to market of futures and option positions, and closing on expiration date are executed by 11:00 on the next day for payments to the TFX accounts at settlement banks. The settlement banks receive and pay out the net amount to TFX's account with the Bank of Japan by 12:00. Payments from the TFX to settlement banks and participants are executed by 12:00 and 14:00, respectively. TFX accounts in all settlement banks are square once all procedures are complete.

With regard to FX derivatives and equity index derivatives, net cash settlements use the client's margin account for all payments of realised and unrealised profit/loss via mark to market and position closing, as well as margin in proportion to the notional amount. Net settlements are executed in the service offices of settlement banks designated by the TFX. Net settlement operates on a T+2 settlement cycle. Payments between clearing members and the TFX are executed by 10:00 on the second day after trades are executed (see Chart 1).

4.3.5.5 Risk management

The TFX manages its exposure to the credit risk posed by participants by setting participation criteria, monitoring participants and maintaining a loss allocation scheme.

The loss allocation scheme for clearing interest rate derivatives comprises the following elements: (i) the defaulters' margin; (ii) the defaulters' clearing fund; (iii) the TFX's default compensation reserve fund; (iv) the remaining clearing funds of non-defaulters; and (v) loss-sharing among non-defaulters. The TFX uses SPAN to calculate the margin amount, which must be posted by 11:00 on the day following the margin requirement. Emergency margin calls are triggered by large price developments. In such cases, participants are required to post their margin by 15:30 on the same day. The required balance of the clearing fund is calculated on the basis of each participant's risk exposure and is subject to a floor of JPY 50 million per participant.

The loss allocation scheme for clearing FX derivatives and equity index derivatives comprises: (i) the defaulter's margin; (ii) the defaulter's clearing fund; (iii) the TFX's default compensation reserve fund; (iv) the remaining clearing funds of non-defaulters; and (v) loss-sharing among non-defaulters. The margin accounts for these contracts include both variation margin for marking to market and initial margin for potential losses arising from the current position. The initial margin required depends on position volume, the price level and price volatility as updated by the TFX.

The TFX manages its exposure to liquidity risk in the event of a participant default through liquidity on hand and overdraft arrangements with commercial banks. For FX derivatives and equity index derivatives, all of the deposits in margin accounts are held as cash to cover emergency liquidity needs in the event of default or a surge in withdrawals by clients and participants with net positive positions.

4.3.5.6 Links to other systems

The TFX has links to the BOJ-NET FTS and the JGB Book-entry System for collateral management. The TFX does not have cross-margin arrangements across CCPs, but provides a clearing service for three-month euroyen futures listed on NYSE Liffe.

4.3.5.7 Pricing

The TFX charges trading fees including clearing service fees based on trading volume measured by units of derivative trades. Fee rates are fixed among derivative products. The TFX also charges a registration fee for obtaining membership and minimum monthly fees for holding membership.

4.3.5.8 Major ongoing and future projects

The TFX plans to introduce new products such as LIBOR futures and equity index derivatives on the FTSE TWSE Taiwan 50. The TFX is also targeting an expansion in foreign members with remote access for interest rate derivatives trading and an increase in domestic and foreign client participation in FX and equity index derivatives trading.

4.4 Securities settlement systems

4.4.1 JGB Book-entry System and BOJ-NET JGB Services

The JGB Book-entry System is an arrangement for processing transfers of JGBs by crediting and debiting accounts on the books of participating institutions. Online processing services for the JGB Book-entry System are provided through BOJ-NET JGB Services. JGB settlements are processed on a DVP basis by linking BOJ-NET JGB Services to the BOJ-NET FTS (see Chart 1). The daily volume and value of transactions settled through BOJ-NET JGB Services averaged 16,000 transactions and JPY 76 trillion (USD 870 billion²³) in 2010.

4.4.1.1 Institutional framework

The JGB Book-entry System is operated by the Bank of Japan as the book-entry transfer institution under the *Book-entry Transfer Act* (see Section 1.1.1.5). BOJ-NET JGB Services, a computer network system, is owned and operated by the Bank of Japan. The Policy Board of the Bank of Japan functions as the ultimate decision-making body for operation of the JGB Book-entry System and BOJ-NET JGB Services.

The legal basis for the Bank of Japan's operation of the JGB Book-entry System is derived from (i) its designation as the book-entry transfer institution by the competent ministers (the commissioner of the FSA to whom the Prime Minister has delegated authority, the Minister of Justice, and the Minister of Finance) under Article 47 of the *Book-entry Transfer Act*; and (ii) authorisation of this operation by the Commissioner of the FSA (to whom the Prime Minister has delegated authority) and the Minister of Finance as an integral part of the Bank of Japan's business, contributing to the smooth settlement of funds as prescribed in Article 39 of the *Bank of Japan Act*. Transfers of JGBs under the JGB Book-entry System are governed by the *Book-entry Transfer Act* and other relevant laws, as well as by rules and procedures established by the Bank of Japan pursuant to these laws.

Pursuant to Article 47 of the *Book-entry Transfer Act*, the Bank of Japan is subject to regulations on book-entry transfer institutions. Unlike other book-entry transfer institutions (stock corporations), however, the Bank of Japan is exempted from regulations regarding the prohibition of other business, the dismissal or disqualification of executives, on-site inspections, and financial reporting and improvement orders, as a special exception permitted by Article 48 of the *Book-entry Transfer Act*.

²³ Converted at yearly average JPY/USD exchange rates for 2010.

4.4.1.2 Participation

The JGB Book-entry System has three types of participants: direct participants, indirect participants and foreign indirect participants (FIP). An FIP is an entity which maintains its account with a direct participant, indirect participant, or FIP as their customer, and which can itself establish an account for its customer outside Japan. Access criteria for the JGB Book-entry System are disclosed to the public and require applicants to be in sound financial condition and have appropriate operational capability. Financial condition is assessed on capital adequacy ratios, and specific criteria are set according to the type of institution. As of June 2011, the JGB Book-entry System had 298 direct participants, 1,015 indirect participants and 128 FIPs.

4.4.1.3 Types of transaction

Only JGBs are processed in the JGB Book-entry System, and payments are made only in yen.

4.4.1.4 Operation of the system

BOJ-NET JGB Services processes final settlements of JGB transfers continuously throughout the day on an RTGS basis, both on a DVP and a free of payment (FOP) basis. The BOJ-NET provides DVP services by linking the BOJ-NET FTS with BOJ-NET JGB Services. The input hours for online instructions and the processing hours for BOJ-NET JGB Services are 09:00–16:30.

The Bank of Japan provides a liquidity-saving facility for DVP settlement, ie simultaneous processing of DVP and collateralisation (SPDC). By using this facility, a financial institution buying JGBs can post the JGBs receiving from the seller as collateral for an intraday overdraft from the Bank of Japan and simultaneously use the funds drawn to pay the seller. JGBs can be posted and returned any time during the operating hours of BOJ-NET JGB Services.

The timing of final settlements of JGB transfers on an RTGS basis through the BOJ-NET is clearly defined by rules set by the Bank of Japan as follows. A transfer of JGBs becomes final when the receiver's JGB account is credited on its transfer account book. The transfer of the corresponding funds becomes final when the current account of the receiver (ie a cash settlement agent) held at the Bank of Japan is credited.

4.4.1.5 Risk management

Debit positions in securities accounts are avoided under the JGB Book-entry System because JGB transfers are made only when the balance in the deliverer's JGB account is sufficient. BOJ-NET JGB Services does not accept transfer instructions that would create debit positions in JGB accounts.

4.4.1.6 Links

The JGB Book-entry System and BOJ-NET JGB Services maintain no direct linkages with overseas FMIs.

4.4.1.7 Pricing

The Bank of Japan covers the costs of developing and maintaining the system infrastructure at its own expense because it operates the JGB Book-entry System and BOJ-NET JGB Services as businesses contributing to the achievement of its objectives under the *Bank of Japan Act*, ie to ensure smooth settlement of funds among banks and other financial institutions (see Section 1.1.1.3). On the other hand, the Bank of Japan charges users of the BOJ-NET JGB Services fees for "online instructions" made through the services under the "beneficiary pays" principle, and recovers the costs of external linkages (such as the costs of

hardware and software necessary for external linkages and the cost of using the online network.

4.4.1.8 Major ongoing and future projects

See Section 3.2.1.7.

4.4.2 Japan Securities Depository Center (JASDEC)

4.4.2.1 Institutional framework

JASDEC started its operation as a securities settlement system with the function of central securities depository in 1991. JASDEC, previously established as a foundation, converted its corporate structure to a stock corporation in January 2002. JASDEC operates the following businesses: (i) book-entry transfer for stocks, commercial papers, corporate bonds, investment trust and other securities excluding Japanese government bonds for which the Bank of Japan provides the settlement system; (ii) a DVP settlement service for those securities; (iii) a pre-settlement matching service; and (iv) custody and settlement services for foreign securities.

JASDEC's largest shareholder is the Tokyo Stock Exchange Group and the second largest is the Japan Securities Dealers Association. Other major shareholders include banks and security companies. Separately from the board of directors and the board of auditors, JASDEC has a business operational committee with 10 subcommittees that represent user needs. Comprising major users, the business operational committee discusses operational matters in line with guidance from JASDEC's board. JASDEC also has an advisory committee comprising external experts.

In 2003, JASDEC established the JASDEC DVP Clearing Corporation (JDCC), a subsidiary for the clearing of customer-side transactions, that is, transactions between securities dealers and institutional investors (see Section 4.3.2).

4.4.2.2 Participation

JASDEC categorises participants of the book-entry transfer business into four groups: (i) issuing companies; (ii) JASDEC participants (securities firms and banks in account with JASDEC); (iii) indirect account management institution (domestic and foreign financial institutions who maintain accounts with a direct account management institutions for holding securities on behalf of their customers); (iv) fund settlement corporations; and (v) others. JASDEC has set up qualification requirements for each category.

As of October 2011, JASDEC had 220 participants in the book-entry transfer system for stocks, and 95 indirect account management institutions (AMIs) including foreign AMIs. The book-entry transfer system for investment trusts has 184 JASDEC participants, 699 indirect AMIs and 83 issuers. The system for corporate bonds has 88 JASDEC participants, 435 indirect AMIs and 2,540 issuers. The book-entry transfer system for commercial paper has 68 JASDEC participants, 39 indirect AMIs and 494 issuers.

4.4.2.3 Types of transaction

JASDEC operates four book-entry transfer systems and a pre-settlement matching system, as well as providing custody and settlement services for foreign securities. The book-entry transfer system for stocks covers bonds with share options, share options, REITs, ETFs and stocks. The book-entry transfer system for corporate bonds also covers municipal bonds and government agency bonds. There are also book-entry transfer systems for commercial paper and investment trusts.

4.4.2.4 Operation of the system

The securities served by JASDEC have been dematerialised and can be settled by DVP through the BOJ-NET or through other cash settlement banks. See below for the operations of the respective systems (see Chart 1).

Book-entry transfer system for CP and corporate bonds

Settlement in the book-entry transfer system for commercial paper and corporate bonds uses DVP1, whereby both delivery of securities at JASDEC and payments of funds at the BOJ-NET FTS are made on a gross real-time basis. To achieve DVP1 for commercial paper and corporate bonds, JASDEC established an operational link between its book-entry system for commercial paper and corporate bonds and the BOJ-NET FTS. Once trade details entered by the buyer and seller are matched in JASDEC's pre-settlement matching system, JASDEC automatically generates settlement instructions. On settlement day, JASDEC transfers the securities from the deliverer's account to the book-entry transfer account, temporarily locking its settlement amount, and sends the request for payment to the BOJ-NET FTS. On receiving JASDEC's request for payment, the BOJ-NET FTS notifies it to the securities receiver (or its settlement bank). After receiving the payment instruction from the securities receiver, the BOJ-NET FTS processes payments of funds from the securities receiver to the securities deliverer. Then the BOJ-NET FTS notifies completion of payments to JASDEC, which releases the previously locked securities and transfers them to the account of the securities receivers. The settlement for commercial paper and corporate bonds takes place from 09:00 to 17:00 (the cut-off time for entering trade details for same-day DVP settlement is 16:20).

Book-entry transfer system for stocks

Two types of DVP model are used for settlement of secondary market stock transactions. Stock transactions executed at stock exchanges (ie transactions between securities firms) must be settled on a DVP3 basis, where both securities and corresponding cash are settled on a net-net basis. On the trade date, transactions are matched by stock exchanges and cleared by JSCC. On settlement day, the resulting net positions in securities are settled at JASDEC, while net positions in cash are settled at the designated cash settlement banks, which comprise a panel of commercial banks and the Bank of Japan (see Section 4.3.1).

Stock transactions in the OTC market (ie transactions between securities firms and institutional investors) can be settled by gross-net DVP (DVP2). Once the trade is executed, the transaction data are matched by JASDEC's pre-settlement matching system and submitted to the JDCC. On the settlement day, the participants' securities positions are settled on a gross basis at JASDEC, while the resulting net cash positions are settled at the BOJ-NET FTS (see Section 4.3.2). For transactions settled on a FOP basis, the participants can send transfer instructions from 09:00 to 15:30 for immediate settlement.

Book-entry transfer system for investment trust

Most transactions settled in the book-entry transfer system for investment trusts are made on a purchase and cancellation basis rather than representing transfers associated with trades between investors. DVP1 can be used for the purchase and cancellation of investment trusts between issuers' trustee banks and fund distributors. To achieve DVP1, a linkage was established between the JASDEC book-entry system for investment trusts and the BOJ-NET FTS. When a funds distributor receives a purchase order from the investor, it passes the order to the issuer. On receiving the order from the funds distributor, the issuer sends JASDEC a request for the order to be recorded. On settlement day, JASDEC records registers the newly created balance on the issuance account, which temporarily records the details of the request from the issuer, and sends the request for payment to the BOJ-NET FTS. The BOJ-NET FTS then notifies the settlement bank of the funds distributor. After receiving the payment instruction from the settlement bank, the BOJ-NET FTS transfers the

payment from the funds distributor to the issuer's trustee bank, and notifies JASDEC of the completed settlement. Upon confirmation from the BOJ-NET FTS, JASDEC records the purchased balances, which are temporarily recorded in the issuance account, on the funds distributor's account. The settlement for investment trusts takes place from 09:00 to 17:00 (the cut-off time for submitting same-day DVP requests for purchase/cancellation to JASDEC is 16:00).

Custody and settlement system for foreign securities

JASDEC provides custody and settlement services for foreign securities listed on stock exchanges in Japan. JASDEC directly or indirectly through local custodians opens accounts with foreign CSDs, holds foreign securities in those accounts on behalf of its participants, and provides custody and settlement services on its own books.

4.4.2.5 Risk management

JASDEC's risk management committee, which is chaired by its president, takes measures to strengthen overall risk management, and regularly monitors internal control systems for various risks including operational risk.

The settlement risk of market participants is mitigated through the use of the DVP mechanism. As the central clearing of stocks is provided by the JSCC and the JDCC, JASDEC is not exposed to counterparty risk from their participants.

4.4.2.6 Links to other systems

To achieve DVP settlement, JASDEC links with the BOJ-NET FTS. JASDEC also directly or indirectly links with foreign CSDs to provide custody and settlement services for foreign stocks.

4.4.2.7 Pricing

JASDEC charges an initial entry fee and a maintenance fee. The fee scale is based on the categorisation of participants (see Section 4.4.2.2) and the volume of transfers processed. The initial entry fee includes the preparation fee for system connection. The maintenance fee is charged only to JASDEC participants and consists of fixed fees such as the fee for system connection, and variable fees such as a transfer fee.

4.4.2.8 Major ongoing and future projects

JASDEC plans to replace its main operating system in 2014. Together with this system replacement, JASDEC and the JDCC plan to start DVP settlement services for stock lending transactions. In the international arena, JASDEC participates in the regional and global CSD forums, and has signed memoranda of understanding with foreign CSDs for the purpose of information-sharing.

4.5 The use of securities infrastructures by the central bank

As well as operating the BOJ-NET JGB Book-entry System, the Bank of Japan uses BOJ-NET JGB Services and JASDEC to carry out central banking activities. The Bank of Japan opens securities accounts with BOJ-NET JGB Services and JASDEC, and uses those systems to manage collateral securities for its various policy operations. The Bank of Japan also provides the intraday liquidity necessary for ensuring smooth settlement in the BOJ-NET Funds Transfer System under its RTGS system, using collateral securities consisting of JGB, commercial paper, corporate bonds and other instruments that meet the Bank of Japan's eligibility criteria. In addition, the Bank of Japan, as a part of its JGB management services, provides the government with issuance services as well as interest/redemption payment services for JGBs. BOJ-NET JGB Services is used for JGB issuance auctions as well as the recording of JGB issuance and redemption.

